

Entanglement-breaking superchannels

Senrui Chen^{1,2} and Eric Chitambar³

¹Department of Electronic Engineering, Tsinghua University, Beijing 100084, China

²Center for Quantum Information, Institute for Interdisciplinary Information Sciences, Tsinghua University, Beijing 100084, China

³Department of Electrical and Computer Engineering, Coordinated Science Laboratory, University of Illinois at Urbana-Champaign, Urbana, IL 61801

In this paper we initiate the study of entanglement-breaking (EB) superchannels. These are processes that always yield separable maps when acting on one side of a bipartite completely positive (CP) map. EB superchannels are a generalization of the well-known EB channels. We give several equivalent characterizations of EB supermaps and superchannels. Unlike its channel counterpart, we find that not every EB superchannel can be implemented as a measure-and-prepare superchannel. We also demonstrate that many EB superchannels can be superactivated, in the sense that they can output non-separable channels when wired in series.

We then introduce the notions of CPTP- and CP-complete images of a superchannel, which capture deterministic and probabilistic channel convertibility, respectively. This allows us to characterize the power of EB superchannels for generating CP maps in different scenarios, and it reveals some fundamental differences between channels and superchannels. Finally, we relax the definition of separable channels to include (p, q) -non-entangling channels, which are bipartite channels that cannot generate entanglement using p - and q -dimensional ancillary systems. By introducing and investigating k -EB maps, we construct examples of (p, q) -EB superchannels that are not fully entanglement breaking. Partial results on the characterization of (p, q) -EB superchannels are also provided.

Senrui Chen: cсенrui@gmail.com

Eric Chitambar: echitamb@illinois.edu

Contents

1	Introduction	3
2	Preliminaries	5
2.1	Notations	5
2.2	Separable and Entanglement-Breaking Maps	6
2.3	Supermaps and Superchannels	6
3	Characterization and Realizations of EBSCs	8
3.1	Characterization of EBSCs	8
3.2	EBSCs realized by EB pre/post-processing maps	10
3.3	EBSCs realized by measure-and-prepare superchannels	14
4	Superactivation of EBSC	17
5	Image of EBSC	18
5.1	CPTP-complete Image of EBSC	19
5.2	CP-complete Image of EBSC	21
5.3	Discussion on CP Image	22
6	Alternative definitions of entanglement breaking	23
6.1	k -Entanglement Breaking Channel	23
6.2	Interplay between k -EBC and $(k, \text{complete})$ -EBSC	26
7	Conclusion and Discussion	27

1 Introduction

Suppose that Alice and Rachel have access to some bipartite quantum channel $\mathcal{E}^{A_0 R_0 \rightarrow A_1 R_1}$. They are interested in using this channel to generate entangled states across their spatially separated laboratories. As shown in Fig. 1, the most general method for doing so would involve using local quantum memories. Alice prepares a locally entangled state $\rho^{A_0 A_E}$, with A_E being her memory register, and Rachel does likewise with the state $\omega^{R_0 R_E}$. Sending systems A_0 and R_0 through the channel leads to the state

$$\sigma^{A_E A_1 : R_E R_1} = \text{id}^{A_E R_E} \otimes \mathcal{E}^{A_0 R_0 \rightarrow A_1 R_1} \left(\rho^{A_0 A_E} \otimes \omega^{R_0 R_E} \right),$$

which they hope is entangled. It is known that such a procedure can be used to generate entanglement if and only if $\mathcal{E}^{A_0 R_0 \rightarrow A_1 R_1}$ does not have the form of a so-called *separable* channel [1]. Hence for Alice and Rachel's goal of obtaining bipartite entangled states, separable channels are completely useless.

Frustrated with the situation, Alice naively wonders if manipulating her part of the channel could improve their prospects of obtaining entanglement. Any physical procedure she attempts can be described as in Fig. 2; it involves her first applying some pre-processing map that couples her input system A_0 to the memory register A_E , and then applying a post-processing map to system A_E and her channel output A_1 [2]. Such a process is known as a superchannel, and specifically here it is a local superchannel since it is being implemented only in Alice's laboratory. Unfortunately for Alice, local superchannels are not able to transform a separable channel into a non-separable one. Consequently, if $\mathcal{E}^{A_0 R_0 \rightarrow A_1 R_1}$ is useless for entanglement generation before Alice's manipulation, it will be useless after. On the other hand, it is quite possible that a local superchannel converts a non-separable channel into a separable one. This begs the question of whether there exist certain local superchannels for Alice that convert *every* bipartite channel into a separable channel. We refer to such processes as *entanglement-breaking superchannels* since they completely eliminate any channel's ability to distribute entanglement, and they are the focus of this paper.

Entanglement-breaking superchannels (EBSCs) generalize the class of entanglement-breaking channels (EBCs), a well-studied object within quantum information theory [3]. A channel $\mathcal{N}^{A_1 \rightarrow B_1}$ is called entanglement breaking (EB) if $\text{id}^{R_1} \otimes \mathcal{N}^{A_1 \rightarrow B_1}(\rho^{R_1 A_1})$ is separable for every $\rho^{R_1 A_1}$ and all systems R_1 . That an EBC is a special case of an EBSC comes from the fact that every quantum state can be regarded as a quantum channel with a one-

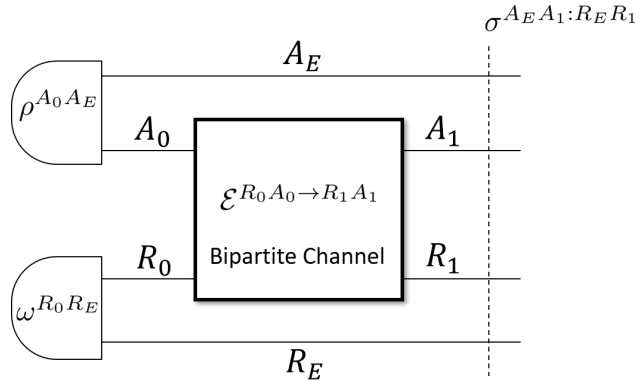

Figure 1: Alice and Rachel can use their bipartite channel \mathcal{E} with local quantum memories to generate entanglement in $\sigma^{A_E A_1 : R_E R_1}$ if and only if \mathcal{E} is not a separable channel.

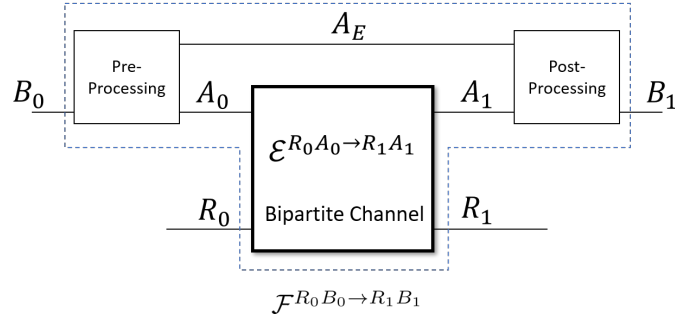

Figure 2: A local superchannel transforms $\mathcal{E}^{R_0 A_0 \rightarrow R_1 A_1}$ into $\mathcal{F}^{R_0 B_0 \rightarrow R_1 B_1}$. An entanglement-breaking superchannel outputs a separable channel for every initial channel.

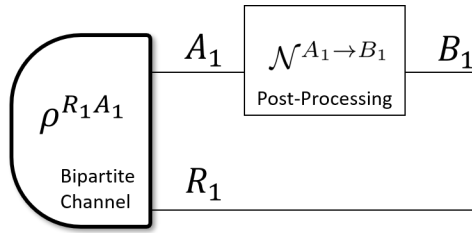

Figure 3: A state $\rho^{R_1 A_1}$ represents a special type of bipartite channel, and a standard EBC can be seen as an EBSC post-processing map.

dimensional input. An EBC $\mathcal{N}^{A_1 \rightarrow B_1}$ can then be seen as an EBSC that locally transforms quantum channels with trivial input (see Fig. 3).

A central theorem is that every EBC can be realized by a measure-and-prepare protocol [3]. That is, $\mathcal{N}^{A_1 \rightarrow B_1}$ is EB if and only if there exists a measurement described by a positive operator-valued measure (POVM) $\{F_k^{A_1}\}_k$ along with a family of states $\{\omega_k^{B_1}\}_k$ such that

$$\mathcal{N}^{A_1 \rightarrow B_1}(\rho^{A_1}) = \sum_k \text{Tr}[F_k^{A_1} \rho^{A_1}] \omega_k^{B_1} \quad (1)$$

for all states ρ^{A_1} of system A_1 . The interpretation is that the EBC $\mathcal{N}^{A_1 \rightarrow B_1}$ can be implemented simply by first measuring system A_1 with POVM $\{F_k^{A_1}\}_k$ and then preparing the state $\omega_k^{B_1}$ contingent on outcome k . A chief question of interest in this paper is whether there exists a similar type of implementation for EBSCs. We find that obvious forms of EBSC implementation fail to capture the entire class of EBSCs, including the generalization of measure-and-prepare channels to superchannels.

The study of EBSCs falls within the broader research program of understanding dynamical quantum resources. A quantum resource theory (QRT) describes a generic framework for isolating some particular feature of a quantum system, like entanglement or coherence, and analyzing how that feature, or “resource”, behaves under a restricted set of operations [4]. Most attention has been previously devoted to studying static resources, that is, features that arise in particular states of a quantum system. However, recently, significant progress has been made in developing the theory of *dynamical* quantum resources, which refer to certain properties of quantum channels that are of interest for quantum information processing [5–9]. For example, in the QRT of entanglement for bipartite channels [10, 11], a channel’s ability to distribute entanglement is a resource, and when separable processing is taken as free, an EBSC can be interpreted as a one-sided resource-erasing map.

The paper is organized as follows. In Section 2, we fix notations and provide neces-

sary preliminaries. In Section 3, we formally define entanglement-breaking superchannels and give several equivalent characterizations. We also characterize a subset of EBSCs which allows for intuitive pre/post-processing realizations. In Section 4, we show how two copies of an EBSC can be combined to no longer be an EBSC, thereby demonstrating a type of superactivation. In Section 5, we introduce the notion of CPTP and CP-complete image and consider what is the largest set of CPTP (CP) maps that can be generated through the action of EBSC, as well as two important subsets of EBSC. In Section 6, we generalize EBSCs to superchannels that output k -non-entangling maps, and we connect these superchannels to the family of k -entanglement-breaking maps, the latter being a type of map that we introduce and thoroughly discuss. We summarize our results and conclude with some discussion in Sec. 7.

2 Preliminaries

2.1 Notations

Throughout this paper we adopt most of the notations used in Ref. [10]. We use capital Latin letters A, B, C , etc. to denote physical systems, and $\mathcal{H}^A, \mathcal{H}^B, \mathcal{H}^C$, etc. to denote their corresponding Hilbert space. Sometimes we also use capital letters to denote Hilbert spaces for simplicity. The collection of all bounded operators on system A will be denoted by $\mathcal{B}(A)$, all Hermitian operators by $\text{Herm}(A)$, all positive operators by $\mathcal{P}(A)$, and all density matrices by $\mathcal{D}(A)$. The set of all linear maps from $\mathcal{B}(A)$ to $\mathcal{B}(B)$ will be denoted as $\mathcal{L}(A \rightarrow B)$, among which all completely-positive maps (CP) and all completely-positive and trace-preserving maps (CPTP) are denoted as $\text{CP}(A \rightarrow B)$ and $\text{CPTP}(A \rightarrow B)$, respectively. A CPTP map is also called a quantum channel.

Since we are considering here dynamical resources, we will always assume that a system A has an associated input and an output system, denoted by A_0, A_1 , respectively. Therefore, we can use the shorthand notation $\mathcal{L}(A) := \mathcal{L}(A_0 \rightarrow A_1)$, $\text{CP}(A) := \text{CP}(A_0 \rightarrow A_1)$, etc. A linear map from $\mathcal{L}(A)$ to $\mathcal{L}(B)$ is called a supermap, and the set of all such supermaps will be denoted by $\mathbb{L}(A \rightarrow B)$. The action of a supermap will be written as a square bracket, like $\Phi[\mathcal{E}]$, whereas the action of quantum channel will usually denoted by round brackets, like $\mathcal{E}(\rho)$.

We use \tilde{A} to denote a system with the same dimension of A , and $\phi_+^{\tilde{A}A} = \sum_{i,j=1}^{d_A} |ii\rangle\langle jj|^{\tilde{A}A}$ is the unnormalized maximally entangled state on space $\tilde{A}A$. For any linear map $\mathcal{E} \in \mathcal{L}(A_0 \rightarrow A_1)$, its Choi matrix is defined as [12, 13]

$$J_{\mathcal{E}}^{A_0 A_1} := \text{id}^{A_0} \otimes \mathcal{E}^{\tilde{A}_0 \rightarrow A_1}(\phi_+^{A_0 \tilde{A}_0}), \quad (2)$$

which establishes an isomorphism between $\mathcal{L}(A_0 \otimes A_1)$ and $\mathcal{L}(A_0 \rightarrow A_1)$, known as the Choi-Jamiolkowski isomorphism. The inverse of Eq. (2) is

$$\mathcal{E}^{A_0 \rightarrow A_1}(\rho^{A_0}) = \text{Tr}_{A_0} \left(\left((\rho^{A_0})^T \otimes I^{A_1} \right) J_{\mathcal{E}}^{A_0 A_1} \right). \quad (3)$$

Furthermore, $\mathcal{E}^{A_0 \rightarrow A_1}$ is a CP map iff $J_{\mathcal{E}}^{A_0 A_1} \geq 0$ (which means it is positive semidefinite), and $\mathcal{E}^{A_0 \rightarrow A_1}$ is TP iff $\text{Tr}_{A_1}(J_{\mathcal{E}}^{A_0 A_1}) = I^{A_0}$.

Throughout this paper, we denote the identity operator on state space \mathcal{H} as I , the identity channel as id (i.e. $\text{id}(\rho) = \rho$), and the identity superchannel as \mathbb{K} (i.e. $\mathbb{K}[\mathcal{E}] = \mathcal{E}$). Hence, when we write $\mathbb{K} \otimes \Theta[\mathcal{E}]$, it should be unambiguously understood as $(\mathbb{K} \otimes \Theta)[\mathcal{E}]$ since \mathbb{K} is a supermap, and should not be confused with $\text{id} \otimes \Theta[\mathcal{E}]$.

2.2 Separable and Entanglement-Breaking Maps

We next review the meaning of separable and entanglement-breaking maps.

Definition 2.1. [14, 15] A CP map $\mathcal{E} \in \text{CP}(A_0 R_0 \rightarrow A_1 R_1)$ is called $A_0 A_1 : R_0 R_1$ **separable** if it can be written as $\mathcal{E} = \sum_k \Phi_k \otimes \Psi_k$ for some $\Phi_k \in \text{CP}(A_0 \rightarrow A_1)$ and $\Psi_k \in \text{CP}(R_0 \rightarrow R_1)$.

It is not difficult to see that $\mathcal{E}^{A_0 R_0 \rightarrow A_1 R_1}$ is separable iff its Choi matrix

$$J_{\mathcal{E}}^{A_0 R_0 A_1 R_1} := \text{id}^{A_0 R_0} \otimes \mathcal{E}^{\tilde{A}_0 \tilde{R}_0 \rightarrow A_1 R_1} (\phi_+^{A_0 \tilde{A}_0} \otimes \phi_+^{R_0 \tilde{R}_0}) \quad (4)$$

is $A_0 A_1 : R_0 R_1$ separable [1]. This means that we can write $J_{\mathcal{E}}^{A_0 A_1 : R_0 R_1} = \sum_k M_k \otimes N_k$ for some $M_k \in \mathcal{P}(A_0 A_1)$ and $N_k \in \mathcal{P}(R_0 R_1)$. As alluded to in the introduction, separability of $\mathcal{E}^{A_0 R_0 \rightarrow A_1 R_1}$ means that it cannot be used for distributing entanglement between Alice and Rachel, and this fact can be most easily established by examining its Choi matrix and using the identity $\mathcal{E}(\rho) = \text{Tr}_{A_0 R_0} [(\rho^{A_0 R_0})^T \otimes I^{A_1 R_1} J_{\mathcal{E}}^{A_0 R_0 A_1 R_1}]$.

A close cousin to the separable maps are those that are entanglement breaking.

Definition 2.2. [3] A CP map $\mathcal{N} \in \text{CP}(A_1 \rightarrow B_1)$ is called **entanglement breaking (EB)** if $\text{id}^{R_1} \otimes \mathcal{N}^{A_1 \rightarrow B_1}(\rho^{R_1 A_1})$ is separable for any $\rho^{R_1 A_1}$ and any system R_1 . An EB map \mathcal{N} is called an **entanglement breaking channel (EBC)** if it is also trace-preserving.

The following provides different characterizations of EB maps and clarifies the relationship between EB and separable maps.

Proposition 2.1. For a CP map $\mathcal{N}^{A_1 \rightarrow B_1}$, the following are equivalent.

- (A) $\mathcal{N}^{A_1 \rightarrow B_1}$ is EB.
- (B) Its Choi matrix $J_{\mathcal{N}}^{A_1 B_1}$ is $A_1 : B_1$ separable.
- (C) $\mathcal{N}^{A_1 \rightarrow B_1}(\rho) = \sum_k \text{Tr}(F_k^{A_1} \rho^{A_1}) \omega_k^{B_1}$, for $F_k^{A_1} \geq 0$ and $\omega_k \in \mathcal{D}(B_1)$.
- (D) For any system R and any bipartite channel $\mathcal{E}^{R_0 B_1 \rightarrow R_1 A_1}$, the composition $\mathcal{F}^{R_0 A_1 \rightarrow R_1 B_1} = \mathcal{N}^{A_1 \rightarrow B_1} \circ \mathcal{E}^{R_0 B_1 \rightarrow R_1 A_1} \circ \mathcal{N}^{A_1 \rightarrow B_1}$ is a separable map.

Proof. Items (A)–(C) are standard results found in Ref. [3]. From the form of Eq. (1), it is easy to see that $J_{\mathcal{F}}^{R_0 A_1 R_1 B_1}$ is $R_0 R_1 : A_1 B_1$ separable whenever \mathcal{N} is EB, and so (A) \Rightarrow (D). Conversely, if (D) holds for all bipartite channels $\mathcal{E}^{R_0 B_1 \rightarrow R_1 A_1}$, then by considering the discard-and-prepare channel $\mathcal{E}(X^{R_0 B_1}) = \text{Tr}[X] \frac{1}{d_{A_1}} \phi_+^{R_1 A_1}$ for $R_1 \cong A_1$, we see that separability of \mathcal{F} implies that \mathcal{N} is EB; hence (D) \Rightarrow (A). \square

Remark: In Section 3.3, we will see that the channel $\mathcal{F}^{R_0 A_1 \rightarrow R_1 B_1}$ constructed in (D) of this proposition is the output of a conditional prepare-and-measure superchannel $\mathcal{E} \mapsto \mathcal{N} \circ \mathcal{E} \circ \mathcal{N}$.

2.3 Supermaps and Superchannels

We next review the basic structure of superchannels. The following definitions and theorems can be found in [16].

Definition 2.3. [2, 16] A supermap $\Theta \in \mathbb{L}(A \rightarrow B)$ is called a **superchannel** if both of the following are satisfied:

(A) Θ is completely CP preserving: $\mathbb{1}^R \otimes \Theta[\mathcal{E}^{RA}]$ is completely positive for any CP map \mathcal{E} and arbitrarily large system R .

(B) Θ is TP preserving: $\Theta[\mathcal{E}]$ is trace preserving for every TP map \mathcal{E} .

We call Θ a **CP supermap** if condition (A) is satisfied.

The notion of *superchannel* defined here is equivalent to the *deterministic supermap* defined in [2], and the term *CP supermap* here is equivalent to *probabilistic supermap* or simply *supermap* in [2]. In contrast to [2], here we use *supermap* to refer to any linear map in $\mathbb{L}(A \rightarrow B)$.

The Choi matrix of a supermap $\Theta^{A \rightarrow B}$ is defined as

$$\mathcal{J}_\Theta^{AB} = \sum_{a_0, a_1} J_{\mathcal{E}_{a_0 a_1}}^A \otimes J_{\Theta[\mathcal{E}_{a_0 a_1}]}^B, \quad (5)$$

where $J_{\mathcal{E}_{a_0 a_1}}^A$ and $J_{\Theta[\mathcal{E}_{a_0 a_1}]}^B$ are the Choi matrices of $\mathcal{E}_{a_0 a_1} \in \mathcal{L}(A)$ and $\Theta[\mathcal{E}_{a_0 a_1}] \in \mathcal{L}(B)$ respectively, and $\{\mathcal{E}_{a_0 a_1}\}_{a_0, a_1}$ is a complete orthogonal basis of $\mathcal{L}(A)$ whose action in the computational basis is given by

$$\mathcal{E}_{ijkl}(\rho^{A_0}) = \langle i | \rho^{A_0} | j \rangle | k \rangle \langle l |^{A_1}. \quad (6)$$

Alternatively, \mathcal{J}_Θ^{AB} equals the Choi matrix of $(\mathbb{1}^A \otimes \Theta^{\tilde{A} \rightarrow B})[\Phi_+^{A\tilde{A}}]$, where

$$\Phi_+^{A\tilde{A}} \equiv \sum_{a_0, a_1} \mathcal{E}_{a_0 a_1}^A \otimes \mathcal{E}_{a_0 a_1}^{\tilde{A}}. \quad (7)$$

The action of $\Phi_+^{A\tilde{A}}$ can be expressed as

$$\Phi_+^{A\tilde{A}}(\rho^{A_0 \tilde{A}_0}) = \text{Tr}(\rho \phi_+^{A_0 \tilde{A}_0}) \phi_+^{A_1 \tilde{A}_1}, \quad (8)$$

and hence it can be viewed as a maximally entangled map, in analogy with ϕ_+ . Note that Φ_+ is not trace-preserving and hence not a quantum channel.

From the Choi-Jamiolkowski duality, there is a one-to-one correspondence between supermaps and their Choi matrix. Hence, the linear spaces $\mathbb{L}(A \rightarrow B)$, $\mathcal{L}(A_0 \otimes A_1 \rightarrow B_0 \otimes B_1)$, $\mathcal{L}(A_0 \otimes B_0 \rightarrow A_1 \otimes B_1)$, and $\mathcal{L}(A_1 \otimes B_0 \rightarrow A_0 \otimes B_1)$ are all isomorphic. We have already seen that $(\mathbb{1}^A \otimes \Theta^{\tilde{A} \rightarrow B})[\Phi_+^{A\tilde{A}}]$ has the same Choi matrix as Θ . Further define $\Delta_\Theta \in \mathcal{L}(A \rightarrow B)$ to be the unique map that satisfies $J_{\Delta_\Theta} = \mathcal{J}_\Theta^{AB}$, and $\Gamma_\Theta \in \mathcal{L}(A_1 B_0 \rightarrow A_0 B_1)$ to be the unique map that satisfies $J_{\Gamma_\Theta} = \mathcal{J}_\Theta^{AB}$. The properties of $\Theta^{A \rightarrow B}$ are then directly related to these three maps. Specifically, Θ is a CP supermap iff $(\mathbb{1} \otimes \Theta)[\Phi_+^{A\tilde{A}}]$, $\Gamma_\Theta^{A_1 B_0 \rightarrow A_0 B_1}$ and $\Delta_\Theta^{A \rightarrow B}$ are CP. The condition when Θ becomes a superchannel is a little bit more involved and is given by the following lemma.

Lemma 2.1. [2, 16] *Let $\Theta \in \mathbb{L}(A \rightarrow B)$. The following are equivalent.*

(A) Θ is a superchannel.

(B) The Choi matrix $\mathcal{J}_\Theta^{AB} \geq 0$ has marginals

$$\mathcal{J}_\Theta^{A_1 B_0} = I^{A_1 B_0}; \quad \mathcal{J}_\Theta^{A B_0} = \mathcal{J}^{A_0 B_0} \otimes u^{A_1} \quad (9)$$

where $u^{A_1} \equiv \frac{1}{d_{A_1}} I^{A_1}$ is the normalized maximally mixed state on A_1 .

(C) There exists a Hilbert space \mathcal{H}_E with $d_E \leq d_{A_0}d_{B_0}$, and two CPTP maps $\Gamma_{\text{pre}}^{B_0 \rightarrow A_0 E}$ and $\Gamma_{\text{post}}^{A_1 E \rightarrow B_1}$ such that for all linear maps \mathcal{E}^A ,

$$\Theta[\mathcal{E}^A] = \Gamma_{\text{post}}^{A_1 E \rightarrow B_1} \circ (\mathcal{E}^A \otimes \text{id}^E) \circ \Gamma_{\text{pre}}^{B_0 \rightarrow A_0 E} \quad (10)$$

For a superchannel $\Theta^{A \rightarrow B}$, one can verify that the Choi matrix of $\Gamma_{\text{post}}^{A_1 E \rightarrow B_1} \circ \Gamma_{\text{pre}}^{B_0 \rightarrow A_0 E}$ is J_{Θ}^{AB} , and hence $\Gamma_{\Theta}^{A_1 B_0 \rightarrow A_0 B_1} = \Gamma_{\text{post}}^{A_1 E \rightarrow B_1} \circ \Gamma_{\text{pre}}^{B_0 \rightarrow A_0 E}$. On the other hand, by the Choi-Jamiołkowski duality we have

$$J_{\Theta[\mathcal{E}]}^B = \text{Tr}_A \left(\mathcal{J}_{\Theta}^{AB} \left((J_{\mathcal{E}}^A)^T \otimes I^B \right) \right). \quad (11)$$

Therefore, the CP map $\Delta_{\Theta}^{A \rightarrow B}$ has a property that it transforms the Choi matrix of a channel to another Choi matrix of a channel, *i.e.* $\Delta_{\Theta}(J_{\mathcal{E}}^A) = J_{\Theta[\mathcal{E}]}^B$.

Pictorially, the calculation of the Choi matrix of a superchannel $\Theta^{A \rightarrow B}$ is shown in Fig 4.

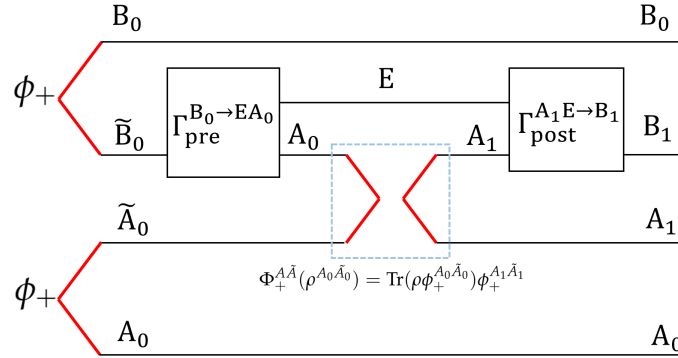

Figure 4: Circuit diagram for calculating the Choi matrix $\mathcal{J}_{\Theta}^{AB}$ of a superchannel $\Theta^{A \rightarrow B}$.

3 Characterization and Realizations of EBSCs

3.1 Characterization of EBSCs

With the background concepts in place from the previous section, we are now able to introduce the notion of entanglement-breaking supermap and entanglement-breaking superchannel.

Definition 3.1. A CP supermap $\Theta^{A \rightarrow B}$ is called an **entanglement-breaking supermap** if $\mathbb{1}^R \otimes \Theta[\mathcal{E}^{RA}]$ is a separable map for every $\mathcal{E} \in CP(RA)$, with R being an arbitrary finite-dimensional system. If $\Theta^{A \rightarrow B}$ is furthermore a superchannel, then it is called an **entanglement-breaking superchannel (EBSC)**.

In this work we primarily focus on EBSCs which is a more physical object. However, in order to better understand the properties of EBSCs, in this and the next subsections, we will also look at EB supermaps. Our first result provides several equivalent characterizations of EB supermaps and EBSCs, in analogy to Proposition 2.1 for EBCs.

Theorem 1. For a CP supermap $\Theta^{A \rightarrow B}$, the following are equivalent.

- (A) $\Theta^{A \rightarrow B}$ is an EB supermap.

(B) $\mathbb{1}^A \otimes \Theta^{\tilde{A} \rightarrow B}[\Phi_+^{A\tilde{A}}]$ is separable for $\Phi_+^{A\tilde{A}}(\rho) = \text{Tr}(\rho \phi_+^{A_0 \tilde{A}_0}) \phi_+^{A_1 \tilde{A}_1}$.

(C) \mathcal{J}_Θ^{AB} is separable with respect to $A : B$.

(D) Θ can be realized with pre/post-processing CP maps $\Gamma_{\text{pre}}^{B_0 \rightarrow A_0 E}$ and $\Gamma_{\text{post}}^{A_1 E \rightarrow B_1}$ such that $\Gamma_\Theta^{A_1 B_0 \rightarrow A_0 B_1} := \Gamma_{\text{post}}^{A_1 E \rightarrow B_1} \circ \Gamma_{\text{pre}}^{B_0 \rightarrow A_0 E}$ is a separable map (with respect to $A_1 A_0 : B_0 B_1$).

(E) $\Delta_\Theta \in \mathcal{L}(A \rightarrow B)$ defined as the unique map with Choi matrix J_Θ^{AB} is an entanglement breaking map.

If Θ is furthermore a superchannel, then the CP conditions in (D) can be strengthened to CPTP.

Sketch of the proof of Theorem 1: (B), (D), (E) correspond to three different CP maps that have the same Choi matrix as Θ , as discussed in Sec. 2, so it is easy to show they are equivalent to (C). (A) \Rightarrow (B) is by definition of EBSCs. (C) \Rightarrow (A) can be shown by considering the Choi matrix of $\mathbb{1} \otimes \Theta[\mathcal{E}]$ for any bipartite CP map \mathcal{E} .

Proof. (A) \Rightarrow (B) is by Def. 3.1 of EBSCs. $\mathbb{1}^A \otimes \Theta^{\tilde{A} \rightarrow B}[\Phi_+^{A\tilde{A}}]$ is separable if and only if its Choi matrix $J_{\mathbb{1} \otimes \Theta[\Phi_+^{A\tilde{A}}]}$ is separable with respect to $A : B$. Since $\mathcal{J}_\Theta^{AB} = J_{\mathbb{1} \otimes \Theta[\Phi_+^{A\tilde{A}}]}$ by definition, we see that (B) \Leftrightarrow (C).

We now prove (C) \Rightarrow (A). For any bipartite map $\mathcal{E}^{RA} \in \text{CP}(R_0 A_0 \rightarrow R_1 A_1)$, according to Eq. (11), we have

$$J_{\mathbb{1} \otimes \Theta[\mathcal{E}]}^{R\tilde{B}} = \text{Tr}_{RA} \left(\mathcal{J}_{\mathbb{1} \otimes \Theta}^{RA\tilde{R}B} \left((J_{\mathcal{E}}^{RA})^T \otimes I^{\tilde{R}B} \right) \right) \quad (12)$$

$$= \text{Tr}_{RA} \left(\left(\phi_+^{R_0 \tilde{R}_0} \otimes \phi_+^{R_1 \tilde{R}_1} \otimes \mathcal{J}_\Theta^{AB} \right) \left((J_{\mathcal{E}}^{RA})^T \otimes I^{\tilde{R}B} \right) \right) \quad (13)$$

$$= \text{Tr}_A \left(\mathcal{J}_\Theta^{AB} \left((J_{\mathcal{E}}^{\tilde{R}A})^{\Gamma_A} \otimes I^B \right) \right), \quad (14)$$

where the superscript Γ_A denotes partial transpose on system A. Since system R is actually unchanged, let $\tilde{R} = R$ and rewrite this equation as

$$J_{\mathbb{1} \otimes \Theta[\mathcal{E}]}^{RB} = \text{Tr}_A \left(\mathcal{J}_\Theta^{AB} \left(J_{\mathcal{E}}^{RA} \right)^{\Gamma_A} \right), \quad (15)$$

where we omit the identity operator. Now \mathcal{J}_Θ^{AB} is separable, which means it can be written as

$$\mathcal{J}_\Theta^{AB} = \sum_{k=1}^K M_k^A \otimes N_k^B \quad (16)$$

for some $M_k^A \in \mathcal{P}(A)$, $N_k^B \in \mathcal{P}(B)$, and positive integer K . Substituting into Eq. (15), we get

$$J_{\mathbb{1} \otimes \Theta[\mathcal{E}]}^{RB} = \sum_k \text{Tr}_A \left(M_k^A \left(J_{\mathcal{E}}^{RA} \right)^{\Gamma_A} \right) \otimes N_k^B, \quad (17)$$

which means $J_{\mathbb{1} \otimes \Theta[\mathcal{E}]}^{RB}$ is separable, and hence $\mathbb{1}^R \otimes \Theta^{A \rightarrow B}[\mathcal{E}^{RA}]$ is separable. Since \mathcal{E}^{RA} is an arbitrary bipartite CP map, we conclude that Θ is an EBSC, which completes the proof of (C) \Rightarrow (A).

This has established the equivalence (A) \Leftrightarrow (B) \Leftrightarrow (C). As for the equivalence of (C), (D), (E), we know that the Choi matrix of $\Gamma_\Theta^{A_1 B_0 \rightarrow A_0 B_1}$ and $\Delta_\Theta^{A \rightarrow B}$ are both \mathcal{J}_Θ^{AB} , as shown in the last section. Therefore, the separability of \mathcal{J}_Θ^{AB} with respect to $A : B$ is

equivalent to the separability of $\Gamma_{\Theta}^{A_1 B_0 \rightarrow A_0 B_1}$ with respect to $A_1 A_0 : B_0 B_1$, which is also equivalent to the fact that $\Delta^{A \rightarrow B}$ is entanglement breaking.

The final remark on the case Θ being a superchannel is by Lemma 2.1 that the pre/post-processing map of Θ can always be chosen to be CPTP (with $\Gamma_{\Theta}^{A_1 B_0 \rightarrow A_0 B_1}$ unchanged). \square

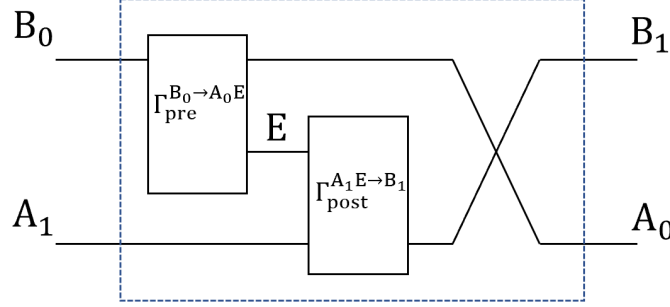

Figure 5: The map $\Gamma_{\Theta}^{A_1 B_0 \rightarrow A_0 B_1} = \Gamma_{\text{post}}^{A_1 E \rightarrow B_1} \circ \Gamma_{\text{pre}}^{B_0 \rightarrow A_0 E}$. For any EB supermap $\Theta^{A \rightarrow B}$, Theorem 1 (D) requires this map to be $A_0 A_1 : B_0 B_1$ separable.

3.2 EBSCs realized by EB pre/post-processing maps

Theorem 1 (D) provides a structural requirement for the pre/post-processing maps of an EBSC. However, the separability on Γ_{Θ} only characterizes the *concatenation* of the pre/post-processing maps, as depicted in Fig. 5. It remains unclear what constraints are placed on the pre/post-processing maps individually in order for the resulting superchannel to be entanglement-breaking. Here, we obtain such a condition when the physical constraint of being trace-preserving is relaxed for the pre/post-processing maps. Namely, we show that the pre/post-processing maps can be expressed as partly entanglement-breaking maps, as defined below. While this provides some mathematical insight into the structure of EBSCs, it is not a statement about physical implementation due to the non-TP property of the maps. When the pre/post-processing maps are required to valid quantum channels, it is unclear whether the pre/post-processing maps can always be taken as party-EB maps. Instead, we show that entanglement needs to be carried by the side channel E that connects the pre and post-processing channels for the implementation of certain EBSCs.

We begin by generalizing the definition of entanglement breaking for CP maps that have bipartite input or output.

Definition 3.2. A CP map $\mathcal{E}^{B_0 \rightarrow A_0 E}$ is called **partly entanglement breaking for output** A_0 if $\text{id}^R \otimes \mathcal{E}^{B_0 \rightarrow A_0 E}(\rho^{RB_0})$ is separable with respect to $A_0 : RE$ for any $\rho \in \mathcal{D}(RB_0)$ and any system R with finite dimension.

Definition 3.3. A CP map $\mathcal{E}^{EA_1 \rightarrow B_1}$ is called **partly entanglement breaking for input** A_1 if $\text{id}^{RS} \otimes \mathcal{E}^{EA_1 \rightarrow B_1}(\sigma^{RE} \otimes \omega^{SA_1})$ is separable with respect to $S : RB_1$ for any $\sigma^{RE} \in \mathcal{D}(RE)$ and $\omega^{SA_1} \in \mathcal{D}(SA_1)$ for any system R, S with finite dimension.

The following two lemmas offer alternative characterizations of partly EB maps, similar to Proposition 2.1 for standard EB maps.

Lemma 3.1. For a CP map $\mathcal{E}^{B_0 \rightarrow A_0 E}$, the following are equivalent:

- (A) $\mathcal{E}^{B_0 \rightarrow A_0 E}$ is partly EB for output system A_0 .

(B) $\text{id}^{B_0} \otimes \mathcal{E}^{\tilde{B}_0 \rightarrow A_0 E}(\phi_+^{B_0 \tilde{B}_0})$ is separable with respect to $A_0 : B_0 E$.

(C) $\mathcal{E}^{B_0 \rightarrow A_0 E}$ can be written as

$$\mathcal{E}^{B_0 \rightarrow A_0 E}(\rho^{B_0}) = \sum_k \mathcal{E}_k^{B_0 \rightarrow E}(\rho^{B_0}) \otimes \sigma_k^{A_0}, \quad (18)$$

for some $\mathcal{E}_k^{B_0 \rightarrow E} \in CP(B_0 \rightarrow E)$ and $\sigma_k^{A_0} \in \mathcal{D}(B)$ independent of the input.

If \mathcal{E} is furthermore CPTP, then $\{\mathcal{E}_k^{B_0 \rightarrow E}\}_k$ in (C) is a quantum instrument, which means $\sum_k \mathcal{E}_k$ is CPTP.

Proof. (A) \Rightarrow (B) is by definition and (C) \Rightarrow (A) is trivial. It remains to prove (B) \Rightarrow (C). Note (B) says that the Choi matrix $J_{\mathcal{E}}^{B_0 A_0 E}$ is separable with respect to $A_0 : B_0 E$. Hence we can write

$$J_{\mathcal{E}}^{B_0 A_0 E} = \sum_k M_k^{B_0 E} \otimes \sigma_k^{A_0} \quad (19)$$

for positive operators $M_k^{B_0 E}$, $\sigma_k^{A_0}$, and without loss of generality, $\text{Tr}(\sigma_k^{A_0}) = 1$ for all k . Taking $\mathcal{E}_k^{B_0 \rightarrow E}$ to be the unique CP map whose Choi matrix equals $M_k^{B_0 E}$ completes the proof. When \mathcal{E} is furthermore CPTP, we have $I^{B_0} = J_{\mathcal{E}}^{B_0} = \sum_k M_k^{B_0}$. Hence, each $M_k^{B_0}$ is the Choi matrix for a CP map $\mathcal{E}_k^{B_0 \rightarrow E}$ and their sum is trace-preserving. \square

Similar conclusions hold for partly EB maps with a bipartite input.

Lemma 3.2. For a quantum maps $\mathcal{E}^{EA_1 \rightarrow B_1}$, the following are equivalent.

(A) $\mathcal{E}^{EA_1 \rightarrow B_1}$ is partly EB for input system A_1 .

(B) $\text{id}^{A_1 E} \otimes \mathcal{E}^{\tilde{A}_1 \rightarrow B_1}(\phi_+^{A_1 \tilde{A}_1} \otimes \phi_+^{E \tilde{E}})$ is separable with respect to $A_1 : EB_1$.

(C) $\mathcal{E}^{EA_1 \rightarrow B_1}$ can be written as

$$\mathcal{E}^{EA_1 \rightarrow B_1}(\rho^{EA_1}) = \sum_k \mathcal{E}_k^{E \rightarrow B_1} \left(\text{Tr}_{A_1}(F_k^{A_1} \rho^{EA_1}) \right). \quad (20)$$

for some $\mathcal{E}_k^{E \rightarrow B_1} \in CP(E \rightarrow B_1)$ and $\{F_k^{A_1}\} \in \mathcal{P}(A_1)$.

If \mathcal{E} is furthermore CPTP, then $\{\mathcal{E}_k^{E \rightarrow B_1}\}_k$ in (C) forms a quantum instrument and $\{F_k^{A_1}\}_k$ forms a POVM.

Proof. The proof is very similar to the previous lemma. We only need to show (B) \Rightarrow (C). For any $\rho \in \mathcal{D}(EA_1)$,

$$\mathcal{E}^{EA_1 \rightarrow B_1}(\rho^{EA_1}) = \text{Tr}_{EA_1}(J_{\mathcal{E}}^{EA_1 B_1}(\rho^{EA_1})^T) \quad (21)$$

$$= \sum_k \text{Tr}_{EA_1} \left((F_k^{A_1})^T \otimes N_k^{EB_1}(\rho^{EA_1})^T \right). \quad (22)$$

Taking $\mathcal{E}_k^{E \rightarrow B_1}$ to be the unique CP map whose Choi matrix equals $N_k^{EB_1}$ completes the proof. When \mathcal{E} is furthermore CPTP, we have that $I^{EA_1} = J_{\mathcal{E}}^{EA_1} = \sum_k (F_k^{A_1})^T \otimes N_k^E$. Hence $\{F_k\}_k$ defines a POVM, and $\{N_k^{EB_1}\}_k$ are Choi matrices for an instrument. \square

Note that partly-EB maps are equivalent to bipartite separable maps with one trivial input/output system. That is, $\mathcal{E}^{B_0 \rightarrow A_0 E}$ is partly EB for output A_0 iff it is a separable map w.r.t. $A_0 : B_0 E$. Similarly, $\mathcal{E}^{E A_1 \rightarrow B_1}$ is partly EB for input A_1 iff $\mathcal{E}^{E A_1 \rightarrow B_1}$ is separable w.r.t. $A_1 : E B_1$. This can be seen from item (B) in Lemmas 3.1 and 3.2. One may also notice from Eq. (18) and Eq. (20) that partly EB channels take a “measure-and-prepare” form. But we must be careful here. Although Eq. (18) can indeed be interpreted as preparing a state conditioned on the measurement outcome, Eq. (20) is like preparing a CPTNI map conditioned on the measurement outcome, which in general cannot be done physically. Even when $\mathcal{E}^{E A_1 \rightarrow B_1}$ is trace-preserving, the individual $\mathcal{E}_k^{E \rightarrow B_1}$ need not be proportional to a trace-preserving map. This is the core reason why EBSCs differ from prepare-and-measure superchannels as will be discussed later.

To see the relevance of partly EB channels to our problem, let us split system E in definitions 3.3 and 3.2 into two parts: $E = E_A E_B$ (see Fig. 6). In this case, $\mathcal{E}^{B_0 \rightarrow A_0 E_A E_B}$ is partly EB for output $A_0 E_A$ iff it is a separable map w.r.t. $A_0 E_A : B_0 E_B$. Similarly, $\mathcal{E}^{E_A E_B A_1 \rightarrow B_1}$ is partly EB for input $A_1 E_A$ iff $\mathcal{E}^{E A_1 \rightarrow B_1}$ is separable w.r.t. $A_1 E_A : B_1 E_B$. Then it is not difficult to show that every EB supermap can be realized with partly-EB pre/post-processing maps of this form.

Theorem 2. For a CP supermap $\Theta \in \mathbb{L}(A \rightarrow B)$, the following are equivalent

- (A) $\Theta^{A \rightarrow B}$ is an EB supermap.
- (B) There exists a CPTP map $\Gamma_{\text{pre}}^{B_0 \rightarrow A_0 E_A E_B}$ that is partly EB for the output system $A_0 E_A$, and a CP map $\Gamma_{\text{post}}^{A_1 E_A E_B \rightarrow B_1}$ that is partly EB for the input system $A_1 E_A$, such that

$$\Theta^{A \rightarrow B}[\mathcal{E}^A] = \Gamma_{\text{post}}^{A_1 E_A E_B \rightarrow B_1} \circ (\mathcal{E}^A \otimes \text{id}^{E_A E_B}) \circ \Gamma_{\text{pre}}^{B_0 \rightarrow A_0 E_A E_B} \quad (23)$$

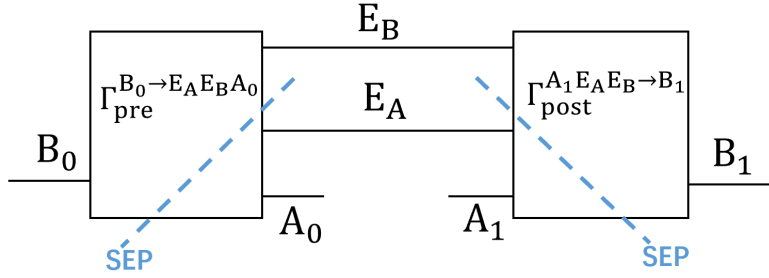

Figure 6: A general way to implement an EB supermap. $\Gamma_{\text{pre}}^{B_0 \rightarrow E_A E_B A_0}$ is partly EB for the output system $E_A A_0$ and $\Gamma_{\text{post}}^{A_1 E_A E_B \rightarrow B_1}$ is partly-EB for the input system $E_A A_1$.

Proof. (B) \Rightarrow (A): As is obvious from Fig. 6, a CP supermap which can be realized as in (B) must be an EB supermap.

(A) \Rightarrow (B): By Theorem 1, the Choi matrix of any EB supermap can be written as

$$\mathcal{J}_{\Theta}^{AB} = \sum_j M_j^A \otimes N_j^B, \quad (24)$$

for $M_j^A \in \mathcal{P}(A)$, $N_j^B \in \mathcal{P}(B)$. Let $E_A \cong A_0$, $E_B \cong B_0$. Define the following pre/post-

processing map

$$\Gamma_{\text{pre}}^{B_0 \rightarrow A_0 E_A E_B}(\rho) = \text{id}^{B_0 \rightarrow E_B}(\rho) \otimes \frac{1}{d_{A_0}} \phi_+^{A_0 E_A}, \quad (25)$$

$$\Gamma_{\text{post}}^{A_1 E_A E_B \rightarrow B_1}(\rho) = d_{A_0} \sum_j \mathcal{N}_j^{E_B \rightarrow B_1} \left(\text{Tr}_{E_A A_1} \left((M_j^{E_A A_1})^T \rho \right) \right), \quad (26)$$

where $\mathcal{N}_j^{B_0 \rightarrow B_1}$ is defined to be the unique CP map whose Choi matrix equals to N_j^B . Obviously these two maps are CPTP and CP respectively.

One can verify that the Choi matrix of $\Gamma_{\text{post}}^{A_1 E_A E_B \rightarrow B_1} \circ \Gamma_{\text{pre}}^{B_0 \rightarrow A_0 E_A E_B}$ equals to $\mathcal{J}_{\Theta}^{AB}$, which means that this pair of pre/post-processing maps indeed implements $\Theta^{A \rightarrow B}$. On the other hand, by Lemma 3.1 and Lemma 3.2, we see these two maps are partly-EB with respect to system $E_A A_0$ and $E_A A_1$, respectively. This completes the proof. \square

The above theorem provides a structural condition on the pre/post-processing maps that can be used to construct any EB supermap. However, it fails to conclude that every EBSC can be realized by a pair of partly-EB pre/post-processing channels since the construction involves a non-TP map in Eq. (26). Nevertheless, we conjecture that it is still possible to realize every EBSC by partly-EB pre/post-processing channels using a different construction than the one given in Theorem 2. We leave this conjecture as an open question to pursue elsewhere. One difficulty in tackling this problem is that the splitting of side channels E into two parts $E = E_A E_B$ makes the general structure of partly-EB pre/post-processing channels rather complex. Here we show that an implementation as in Fig. 6 but with E_A removed is not strong enough to implement all EBSCs. Hence, implementing an EBSC will in general requires entanglement to be distributed across a memory side channel. To see this, we first make a simple observation.

Proposition 3.1. *Suppose that Θ is a superchannel realized by a partly EB pre-processing map $\Gamma_{\text{pre}}^{B_0 \rightarrow A_0 E}$ for A_0 and any CPTP post-processing map $\Gamma_{\text{post}}^{E A_1 \rightarrow B_1}$. Then for any ρ^{RB_0} and ω^{SA_1} , the output state*

$$\text{id}^{RS} \otimes \Gamma_{\text{post}}^{E A_1 \rightarrow B_1} \circ \Gamma_{\text{pre}}^{B_0 \rightarrow A_0 E} \left(\rho^{RB_0} \otimes \omega^{SA_1} \right) \quad (27)$$

is separable across $A_0 : RB_1 S$. Similarly, if Θ is realized by a partly EB post-processing map for A_1 , then this output state is separable across $A_0 RB_1 : S$.

Proof. By definition, $\sigma^{A_0:RE} = \text{id}^R \otimes \Gamma_{\text{pre}}^{B_0 \rightarrow A_0 E} \left(\rho^{RB_0} \right)$ is separable across $A_0 : RE$. Then $\text{id}^S \otimes \Gamma_{\text{post}}^{E A_1 \rightarrow B_1} (\sigma^{A_0:RE} \otimes \omega^{SA_1})$ will also be separable across $A_0 : RB_1 S$. An analogous argument proves the second statement when the post-processing map is partly EB. \square

From this proposition, it follows that if $\Theta^{A \rightarrow B}$ is an EBSC that can be realized by a partly EB pre-processing (resp. post-processing) map for system A_0 (resp. system A_1), then we must have that $\mathcal{J}_{\Theta}^{AB}$ is both $A_0 A_1 : B_0 B_1$ separable as well as $A_0 : A_1 B_0 B_1$ (resp. $A_1 : A_0 B_0 B_1$) separable. It is not difficult to construct superchannels that fail to have this separability structure.

Theorem 3. *There exist EBSCs that cannot be realized using either a pre-processing channel that is partly EB for A_0 or a post-processing channel that is partly EB for A_1 . In other words, in Fig. 6, input system A_0 must be entangled with some side channel E_A and output system A_1 must couple with E_A nonlocally.*

Proof. By the previous proposition, it suffices to construct pre/post-processing maps $\Gamma_{\text{pre}}^{B_0 \rightarrow A_0 E}$ and $\Gamma_{\text{post}}^{E A_1 \rightarrow B_1}$ such that

$$\mathcal{J}_{\Theta}^{AB} = \text{id}^{B_0 A_1} \otimes \Gamma_{\text{post}}^{E \tilde{A}_1 \rightarrow B_1} \circ \Gamma_{\text{pre}}^{\tilde{B}_0 \rightarrow A_0 E} \left(\phi^{+A_1 \tilde{A}_1} \otimes \phi^{+B_0 \tilde{B}_0} \right)$$

is $A_0 A_1 : B_0 B_1$ separable, but neither $A_0 : A_1 B_0 B_1$ nor $A_1 : A_0 B_0 B_1$ is separable. Let $d_{B_0} = d_{A_0} = d_{A_1} = 2$ and $d_{B_1} = d_E = 3$. Define the isometry $\Gamma_{\text{pre}}^{\tilde{B}_0 \rightarrow A_0 E}$ by

$$|0\rangle^{\tilde{B}_0} \rightarrow \frac{1}{\sqrt{2}}(|00\rangle + |11\rangle)^{A_0 E}, \quad |1\rangle^{\tilde{B}_0} \rightarrow |02\rangle^{A_0 E}. \quad (28)$$

Hence $\text{id}^{B_0} \otimes \Gamma_{\text{pre}}^{\tilde{B}_0 \rightarrow A_0 E}(\phi^{+B_0 \tilde{B}_0}) = |\tau\rangle\langle\tau|$, where $|\tau\rangle = \frac{1}{\sqrt{2}}(|00\rangle + |11\rangle)^{A_0 E} |0\rangle^{B_0} + |02\rangle^{A_0 E} |1\rangle^{B_0}$. The post-processing map $\Gamma_{\text{post}}^{E \tilde{A}_1 \rightarrow B_1}$ is then a POVM with elements

$$\begin{aligned} \Pi_0 &= \frac{1}{2} \phi^{+E \tilde{A}_1}, \\ \Pi_1 &= (I - |2\rangle\langle 2|)^E \otimes I^{\tilde{A}_1} - \frac{1}{2} \phi^{+E \tilde{A}_1} \\ \Pi_2 &= |2\rangle\langle 2|^E \otimes I^{\tilde{A}_1}. \end{aligned} \quad (29)$$

This leads to the Choi matrix

$$\begin{aligned} \mathcal{J}_{\Theta}^{AB} &= \frac{1}{4} \phi^{+A_0 A_1} \otimes |00\rangle\langle 00|^{B_0 B_1} + \frac{1}{2} \left(I^{A_0 A_1} - \frac{1}{2} \phi^{+A_0 A_1} \right) \otimes |01\rangle\langle 01|^{B_0 B_1} \\ &\quad + |0\rangle\langle 0|^{A_0} \otimes I^{A_1} \otimes |12\rangle\langle 12|^{B_0 B_1}. \end{aligned} \quad (30)$$

Clearly it is $A : B$ separable, and yet it is entangled for both parts A_0 and A_1 since projecting onto $|00\rangle^{B_0 B_1}$ leads to the maximally entangled state $\frac{1}{4} \phi^{+A_0 A_1}$. \square

3.3 EBSCs realized by measure-and-prepare superchannels

On the level of channels, entanglement-breaking is equivalent to measuring and preparing, as described in Eq. (1). A natural question is whether the same holds for EBSCs. To this end, we first need a generalized notion of measurement that also applies to dynamical resources. Recall that a quantum instrument is a collection of CP maps $\{\mathcal{E}_k\}_k$ whose sum $\sum_k \mathcal{E}_k$ is TP. For a generalized measurement on state ρ described by instrument $\{\mathcal{E}_k\}_k$, outcome k occurs with probability $p_k = \text{Tr}[\mathcal{E}_k(\rho)]$ and the post-measurement state is $\mathcal{E}_k(\rho)/p_k$. In Ref. [17], the authors introduce the concept of a *quantum super-instrument*, which is a set of c-CPTNI (completely CP preserving and trace-non-increasing preserving) supermaps $\{\Theta_x\}$ such that $\sum_x \Theta_x$ is a superchannel. A quantum super-instrument therefore describes in one sense how a quantum channel can be measured. It is proven in [17] that every super-instrument can be realized with a CPTP pre-processing channel and a post-processing quantum instrument, as shown on the left side of Fig. 7. We are particularly interested in a special kind of super-instrument with trivial output channel, which is a generalization of the positive operator-valued measurement (POVM) to quantum channels, as shown on the right side of Fig. 7. Such object has been considered in the study of quantum channel discrimination [18, 19] where it is called a tester or a process-POVM, and in the study of quantum games [20] where it is called a co-strategy.

With the concept of a channel POVM in place, we next combine it with a channel preparation step to obtain a measure-and-prepare superchannel. This is depicted in Fig. 8 where the channel \mathcal{F}_x^B is prepared contingent on the outcome x of the preceding channel POVM.

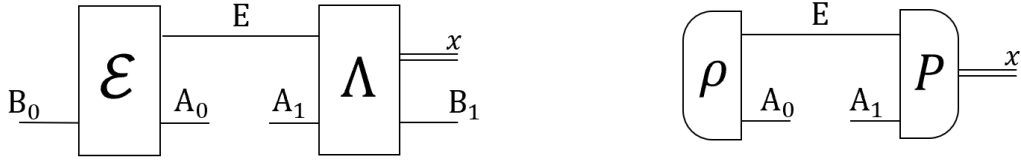

Figure 7: (Left) Implementation of a quantum super-instrument. A CPTP map \mathcal{E} is performed as pre-processing while a quantum instrument $\Lambda = \sum_x \Lambda_x \otimes |x\rangle\langle x|$ encompasses the post-processing. (Right) A POVM of quantum channels. The pre-processing is a quantum state ρ and the post processing is a bipartite measurement channel $P = \sum_x \text{Tr}_x(\cdot P_x) \otimes |x\rangle\langle x|$ for POVM $\{P_x\}_x$.

Definition 3.4. A superchannel $\Theta^{A \rightarrow B}$ is called a *measure-and-prepare superchannel (MPSC)* if it can be realized as

$$\Theta^{A \rightarrow B}[\mathcal{E}^A] = \sum_x \text{Tr} \left(\text{id}^E \otimes \mathcal{E}^A(\rho^{A_0 E}) P_x^{A_1 E} \right) \mathcal{F}_x^B, \quad (31)$$

where $\rho^{A_0 E}$ is some quantum state, $\{P_x^{A_1 E}\}$ is some POVM, and $\{\mathcal{F}_x^B\}$ is a collection of CPTP maps.

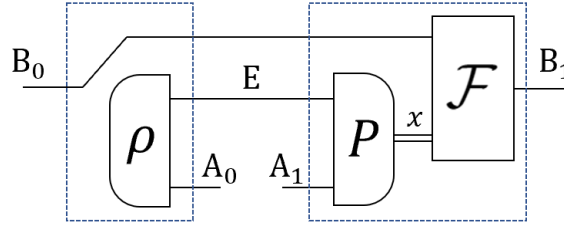

Figure 8: A measure-and-prepare superchannel (MPSC).

There is a good physical motivation to consider MPSCs from the point of view of quantum memories. An experimenter might want to transform an input channel \mathcal{E}^A into a new channel that could be used at some later time. For an MPSC, no quantum memory is needed to accomplish this goal. Input channel \mathcal{E}^A can be processed at time t_0 with output x stored in classical memory. Then at some later time t_1 , system B_0 can be directly processed by map \mathcal{F}_x . Note, for this interpretation to hold, it is crucial that \mathcal{F}_x be trace-preserving.

In the definition of an MPSC, the choice of pre-processing state $\rho^{E_1 A_0}$ provides an extra degree of freedom that is not present in the channel case. Furthermore, the state $\rho^{E_1 A_0}$ is independent of the input system B_0 . One may also want to apply a quantum instrument on B_0 and generate different pre-processing states conditioned on the measurement outcome of this instrument. We will refer to a superchannel having this type of structure as a controlled measure-and-prepare superchannel, or CMPSC for short. Its rigorous definition is as follows.

Definition 3.5. A superchannel $\Theta^{A \rightarrow B}$ is called a *controlled measure-and-prepare superchannel (CMPSC)* if it can be realized as

$$\Theta^{A \rightarrow B}[\mathcal{E}^A] = \sum_{xy} \text{Tr} \left(\text{id}^{E_1} \otimes \mathcal{E}^A(\rho_y^{A_0 E_1}) P_x^{A_1 E_1} \right) \mathcal{F}_x^{E_2 \rightarrow B_1} \circ \Lambda_y^{B_0 \rightarrow E_1}, \quad (32)$$

where $\{\Lambda_y\}_y$ is a quantum instrument, $\rho_y^{A_0 E_1}$ is some quantum state, $\{P_x^{A_1 E_1}\}_x$ is a POVM, and $\{\mathcal{F}_x\}_x$ is a family of CPTP maps.

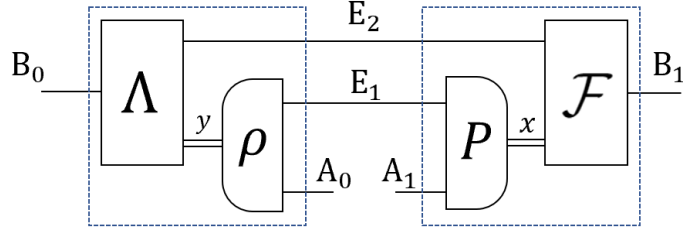

Figure 9: A controlled measure-and-prepare superchannel (CMPSC).

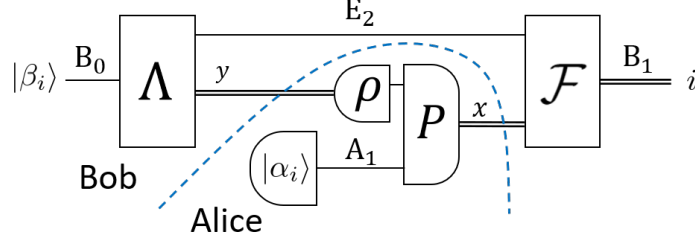

Figure 10: When A_0 is one-dimensional, a CMPSC reduces to a 2-way LOCC map on product states. Since there are separable maps that cannot be implemented by 2-way LOCC, there exist EBSCs that are not CMPSCs.

The realization of a CMPSC is shown in Fig. 9.

One can easily verify that every CMPSC is an EBSC. It is therefore natural to conjecture that every EBSC can be realized as an MPSC, similar to the case of EBCs. However, we will now show below that this conjecture fails to be true.

Theorem 4. *There exist EBSCs that are not CMPSC.*

Proof. The construction uses the fact that there exist channels $\mathcal{E}^{E_2 A_1 \rightarrow B_1}$ that are partly EB for A_1 , yet they are not implementable by local operations and classical communication (LOCC). From the remark following Lemma 3.1, a partly EB channel for input A_1 is an $A_1 : E_2 B_1$ separable channel. Let $\mathcal{E}^{E_2 A_1 \rightarrow B_1}$ be any such channel whose action on a collection of product states $\{|\alpha_i\rangle^{A_1} \otimes |\beta_i\rangle^{E_2}\}$ cannot be simulated by LOCC. Such maps arise, for instance, when considering orthogonal product bases that can be distinguished by separable operations but not LOCC, a phenomenon famously known as *nonlocality without entanglement* [21]. Another example is the so-called double-trine ensemble [22], given by $|\alpha_i\rangle = |\beta_i\rangle = U^i|0\rangle$ for $i = 0, 1, 2$, where $U = \exp(-i\frac{\pi}{3}\sigma_y)$. While an optimal minimum-error discrimination measurement on $\{|\alpha_i\rangle \otimes |\beta_i\rangle\}_{i=0,1,2}$ can be achieved by a separable map, it cannot be implemented by LOCC [23]. Let $\mathcal{E}^{E_2 A_1 \rightarrow B_1}$ be any such non-LOCC channel whose action is

$$\mathcal{E}^{E_2 A_1 \rightarrow B_1} : |\alpha_i\rangle|\beta_i\rangle \mapsto \rho_i$$

for all i . We can regard this as a post-processing map for a superchannel that converts each state $|\alpha_i\rangle$ into a QC channel having action $|\beta_i\rangle \rightarrow \rho_i$. Since $\mathcal{E}^{E_2 A_1 \rightarrow B_1}$ is separable, it is clearly an EBSC. However, with system A_0 being one-dimensional, the possible implementation by a CMPSC reduces to two-way LOCC, as shown in Fig. 10, which is not possible by construction. Therefore the superchannel is not CMPSC. \square

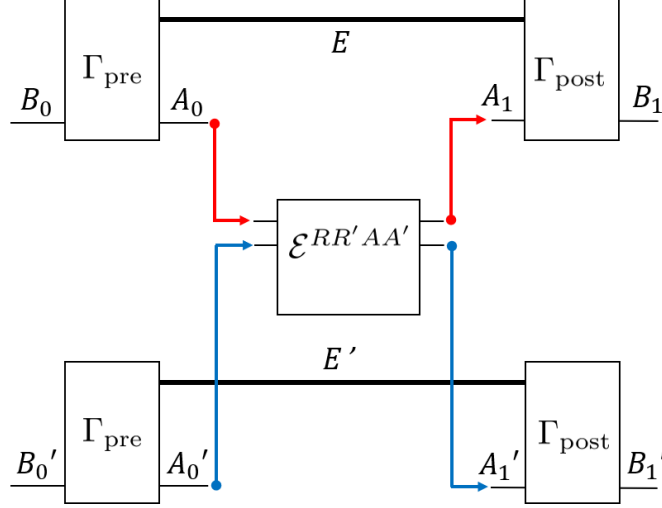

Figure 11: A parallel implementation of two EBSCs is still an EBSC.

4 Superactivation of EBSC

Entanglement-breaking channels have the property that they are closed under tensor product. That is, if $\mathcal{E}^{A_0 \rightarrow A_1}$ and $\mathcal{N}^{R_0 \rightarrow R_1}$ are both EB channels, then so is their tensor product, $[\mathcal{E} \otimes \mathcal{N}]^{A_0 R_0 \rightarrow A_1 R_1}$. In this section we consider whether an analogous result holds for EBSCs. The problem has an added level of complexity when dealing with superchannels since the dynamic nature of channels allows them to be processed in different ways. On the one hand, two copies of a superchannel can be used for parallel processing, which means that their pre/post-processing occurs simultaneously, as shown in Fig. 11. Alternatively, the two superchannels can implement a processing of channels in series, such that the output of one superchannel can be used as the input for the other, as shown in Fig. 12. While the full theory of sequential processing can be described using the formalism of quantum combs [24, 25] or quantum strategies [20, 26, 27], here we do not need to invoke these to demonstrate the generic superactivation of EBSC.

Theorem 5. *Suppose $\Theta^{A \rightarrow B}$ is an EBSC. Then two copies of $\Theta^{A \rightarrow B}$ will be an EBSC when used in parallel. However, if $\mathcal{J}_{\Theta}^{A_1 B_0 B_1}$ is entangled across $A_1 B_0 : B_1$ and $d_{A_1} \geq d_{B_0}$, then two copies of $\Theta^{A \rightarrow B}$ is no longer an EBSC when used in series.*

Proof. When two copies of $\Theta^{A \rightarrow B}$ are used in parallel, they become a single superchannel $\Theta^{AA' \rightarrow BB'}$. Its Choi matrix satisfies $\mathcal{J}_{\Theta}^{AA' BB'} = \mathcal{J}_{\Theta}^{AB} \otimes \mathcal{J}_{\Theta}^{A' B'}$, and since two copies of a separable operator is separable, it follows that $\mathcal{J}_{\Theta}^{AA' BB'}$ represents an EBSC. On the other hand, suppose that each copy of $\Theta^{A \rightarrow B}$ can be used in series. Let $d_{R_0} = d_{A_0}$, $d_{R_1} = d_{A_1}$, and define the channel \mathcal{E}_0^{RA} that discards its input and prepares the state $\frac{1}{d_{B_0}} \phi_+^{R_1 B'_0}$. Likewise, let $\mathcal{E}_1^{R'A'}$ be the channel that discards and prepares $\frac{1}{d_{A_1}} \phi_+^{R'_1 A'_1}$. Then with the wiring shown in Fig. 12, it follows that the resulting channel will be the state

$$\Omega^{R_1 R'_1 B'_1} = d_{B_0}^{-1} d_{A_1}^{-1} \text{Tr}_{A'_0} \left(\text{id}^{R'_1} \otimes \Gamma_{\text{post}}^{EA'_1 \rightarrow B'_1} \circ \text{id}^{R_1} \otimes \Gamma_{\text{pre}}^{B'_0 \rightarrow A'_0 E} \left(\phi_+^{R_1 B'_0} \otimes \phi_+^{R'_1 A'_1} \right) \right). \quad (33)$$

However, this is proportional to $\mathcal{J}_{\Theta}^{A'_1 B'_0 B'_1}$ with A'_1 replaced by R'_1 and B'_0 replaced by R_1 . The $A'_1 B'_0 : B'_1$ entanglement implies that $\Omega^{R_1 R'_1 B'_1}$ is entangled between Rachel and Bob. Hence \mathcal{E}_0^{RA} and $\mathcal{E}_1^{R'A'}$ is transformed into an entangled channel by two copies of the EBSC $\Theta^{A \rightarrow B}$. \square

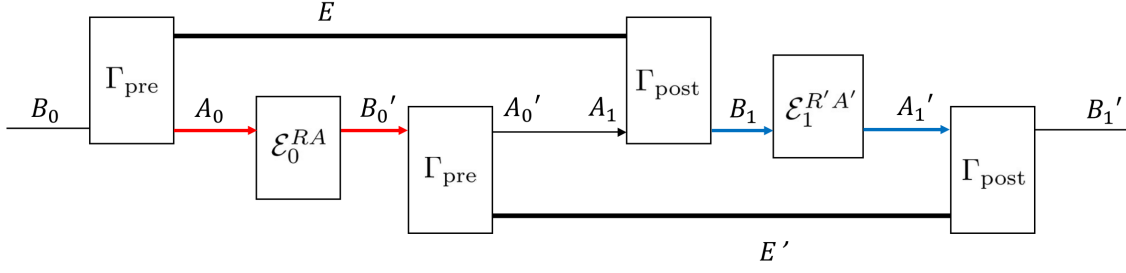

Figure 12: A series implementation of two EBSCs that can yield a non-separable channel. The channels \mathcal{E}_0^{RA} and $\mathcal{E}_1^{R'A'}$ discard their inputs and prepare maximally entangled states.

5 Image of EBSC

In Section 3 we introduced EBSC and its two subsets MPSC and CMPSC. Here, we investigate the comparative powers of these operational classes. In particular, we consider whether every bipartite separable channel can be generated by applying an EBSC on one part of some bipartite channel, and whether MPSC/CMPSC has the same channel-generation power as EBSC. For this purpose, we introduce the notion of *CPTP-complete image*.

Definition 5.1. Given a superchannel $\Theta^{A \rightarrow B}$, the **CPTP image** of $\Theta^{A \rightarrow B}$ is defined as

$$\text{Im}_\Theta = \left\{ \mathcal{G}^B \in \text{CPTP}(B) \mid \mathcal{G}^B = \Theta^{A \rightarrow B}[\mathcal{E}^A], \mathcal{E}^A \in \text{CPTP}(A) \right\}. \quad (34)$$

The **CPTP-complete image** of $\Theta^{A \rightarrow B}$ is defined as

$$\text{C}_\Theta = \bigcup_R \text{Im}_{\mathbb{1}^R \otimes \Theta}, \quad (35)$$

which is the union of CPTP images $\mathbb{1}^R \otimes \Theta^{A \rightarrow B}$ for all systems R . The **CPTP-complete image** of a set of superchannels \mathcal{S} is defined as $\text{C}_\mathcal{S} = \bigcup_{\Theta \in \mathcal{S}} \text{C}_\Theta$.

Similarly, we introduce the *CP-complete image* as follows.

Definition 5.2. Given a superchannel $\Theta^{A \rightarrow B}$, the **CP image** of $\Theta^{A \rightarrow B}$ is defined as

$$\text{Im}_\Theta^* = \left\{ \mathcal{G}^B \in \text{CP}(B) \mid \mathcal{G}^B = \Theta^{A \rightarrow B}[\mathcal{E}^A], \mathcal{E}^A \in \text{CP}(A) \right\}. \quad (36)$$

The **CP-complete image** of $\Theta^{A \rightarrow B}$ is defined as

$$\text{C}_\Theta^* = \bigcup_R \text{Im}_{\mathbb{1}^R \otimes \Theta}^*, \quad (37)$$

which is the union of CP images $\mathbb{1}^R \otimes \Theta^{A \rightarrow B}$ for all systems R . The **CP-complete image** of a set of superchannels \mathcal{S} is defined as $\text{C}_\mathcal{S}^* = \bigcup_{\Theta \in \mathcal{S}} \text{C}_\Theta^*$.

Alternatively, we can say that the CPTP image of $\Theta^{A \rightarrow B}$ is its image when the domain is restricted to CPTP maps, and likewise the CP image of $\Theta^{A \rightarrow B}$ is its image when the domain is restricted to CP maps.

With these definitions in place, a superchannel $\Theta^{A \rightarrow B}$ is an EBSC if and only if $\text{C}_\Theta^* \subseteq \text{SEP}^*$. Here we use SEP^* to denote the set of separable CP maps while SEP denotes the set of all separable CPTP maps. An interesting question is whether $\text{C}_{\text{EBSC}} = \text{SEP}$ and $\text{C}_{\text{EBSC}}^* = \text{SEP}^*$ hold, which will be the main concern of this section.

Let us first consider this question for EBCs. Note that our definition of CPTP (CP) complete image also applies for channels since they are a special case of superchannels. Specifically, for a channel \mathcal{E} , the set $\text{Im}_{\mathcal{E}}$ (resp. $\text{Im}_{\mathcal{E}}^*$) is the image of \mathcal{E} when the domain is restricted to density operators (resp. positive operators). In this case, it is easy to see that both $\text{C}_{\text{EBC}} = \text{SEP}$ and $\text{C}_{\text{EBC}}^* = \text{SEP}^*$ hold. Indeed for an arbitrary separable positive operator $\rho^{RB} = \sum_i p_i |\psi_i\rangle\langle\psi_i|^R \otimes |\alpha_i\rangle\langle\alpha_i|^B$, one need only consider the action of the EBC $\mathcal{E}^{A \rightarrow B}$ on the positive operator $\sigma^{RA} = \sum_i p_i |\psi_i\rangle\langle\psi_i|^R \otimes |i\rangle\langle i|^A$, where $\mathcal{E}^A(X) = \langle i|X|i\rangle^A |\alpha_i\rangle\langle\alpha_i|^B$, and σ^{RA} is a density matrix if and only if ρ^{RB} is.

In following part of this section, we set out to study the image of general EBSC. Regarding the CPTP-complete image, while we are unable to precisely characterize C_{EBSC} , we relate C_{MPSC} and C_{CMPSC} to LOCC channels of certain communication rounds. As for the CP-complete image, we show that $\text{C}_{\text{EBSC}}^* = \text{SEP}^*$ holds exactly. These results reveal some fundamental differences between channels and superchannels of physical significance, and we discuss this further at the end of this section.

5.1 CPTP-complete Image of EBSC

As noted above, one of our primary interests is determining whether $\text{C}_{\text{EBSC}} = \text{SEP}$. We consider here a special subset of the separable channels that can be generated by LOCC. While LOCC is a notoriously difficult class of operations to analyze, here it will be sufficient to just consider one-round and two-round LOCC. A precise definition of these operational classes is as follows.

Definition 5.3. [28] *A channel $\mathcal{E} \in \text{CPTP}(R_0 B_0 \rightarrow R_1 B_1)$ is called a $(B \rightarrow R \rightarrow B)$ two-round LOCC channel if it can be written as*

$$\mathcal{E}^{RB} = \sum_{ij} \Gamma_{j|i}^{R_0 \rightarrow R_1} \otimes (\mathcal{F}_{ij}^{B_2 \rightarrow B_1} \circ \Lambda_i^{B_0 \rightarrow B_2}) \quad (38)$$

for some quantum instrument $\{\Lambda_i^{B_0 \rightarrow B_2}\}_i$ and family of channels $\{\mathcal{F}_{ij}^{B_2 \rightarrow B_1}\}_{ij}$ for Bob, and a family of instruments $\{\Gamma_{j|i}^{R_0 \rightarrow R_1}\}_{i,j}$ for Rachel. An $(R \rightarrow B)$ one-way LOCC channel is defined similarly except with the added condition that all the Λ_i are trivial; i.e. $\mathcal{E}^{RB} = \sum_j \Gamma_j^R \otimes \mathcal{F}_j^B$.

Proposition 5.1. *The CPTP-complete images of EBSC, MPSC and CMPSC satisfy the following relation.*

$$\text{C}_{\text{MPSC}} = \text{LOCC}_1 \subsetneq \text{LOCC}_2 = \text{C}_{\text{CMPSC}} \subsetneq \text{C}_{\text{EBSC}} \subseteq \text{SEP}, \quad (39)$$

where LOCC_1 denotes the set of all $(R \rightarrow B)$ one-round LOCC channels, LOCC_2 denotes the set of all $(B \rightarrow R \rightarrow B)$ two-round LOCC channels, and SEP denotes the set of all bipartite separable channels.

Proof. For the second equality, first notice that if Θ is CMPSC, then $\mathbf{1} \otimes \Theta[\mathcal{E}]$ is a two-round LOCC channel for every quantum channel \mathcal{E}^{RA} , as can be seen from Fig. 13. This establishes $\text{C}_{\text{CMPSC}} \subseteq \text{LOCC}_2$. On the other hand, consider an arbitrary $(B \rightarrow R \rightarrow B)$ two-round LOCC channel \mathcal{G} . By definition 5.3, it can be written as

$$\mathcal{G}^{RB} = \sum_{ij} \Gamma_{j|i}^R \otimes (\mathcal{F}_{ij}^{B_2 \rightarrow B_1} \circ \Lambda_i^{B_0 \rightarrow B_2}) \quad (40)$$

for some CPTP maps \mathcal{F}_{ij}^B and deterministic quantum instruments $\{\Lambda_i^B\}$, $\{\Gamma_{j|i}^R\}$. Set $B_2 = E_2$ and construct a superchannel Θ with the following realization:

$$\Gamma_{\text{pre}}^{B_0 \rightarrow A_0 \hat{E}_2 E_2}(\cdot) = \sum_i |i\rangle\langle i|^{A_0} \otimes |i\rangle\langle i|^{\hat{E}_2} \otimes \Lambda_i^{B_0 \rightarrow E_2}(\cdot), \quad (41)$$

$$\Gamma_{\text{post}}^{A_1 \hat{E}_2 E_2 \rightarrow B_1}(\cdot) = \sum_{i,j} \langle j| \cdot |j\rangle^{A_1} \langle i| \cdot |i\rangle^{\hat{E}_2} \mathcal{F}_{ij}^{E_2 \rightarrow B_1}(\cdot). \quad (42)$$

Here, system E_1 is taken to be trivial. It is easy to see that Θ is a CMPSC by Def. 3.5. Then consider the quantum channel

$$\mathcal{E}^{RA}(\cdot) = \sum_{ij} \Gamma_{j|i}^R(\cdot) \otimes \langle i| \cdot |i\rangle^{A_0} \otimes |j\rangle\langle j|^{A_1}. \quad (43)$$

One can immediately verify that $\mathcal{G}^{RB} = \mathbb{1}^R \otimes \Theta^{A \rightarrow B}[\mathcal{E}^{RA}]$, which means $\mathcal{G}^{RB} \in \mathcal{C}_{\text{CMPSC}}$. By the arbitrariness of \mathcal{G} we have $\text{LOCC}_2 \subseteq \mathcal{C}_{\text{CMPSC}}$, hence $\text{LOCC}_2 = \mathcal{C}_{\text{CMPSC}}$.

For the first equality in Eq. (39), we can similarly verify that $\mathcal{C}_{\text{MPSC}} \subseteq \text{LOCC}_1$ from Fig. 13 when the classical channel from Bob to Rachel is removed. For an arbitrary $(R \rightarrow B)$ one-way LOCC channel $\mathcal{G}^{RB} = \sum_i \Gamma_i^R \otimes \mathcal{F}_i^B$ with CPTP maps \mathcal{F}_i and quantum instrument $\{\Gamma_i\}_i$, construct a superchannel $\Theta^{A_1 \rightarrow B}$ with trivial A_0 system as

$$\Theta^{A_1 \rightarrow B}[\cdot] = \sum_i \langle i| \cdot |i\rangle^{A_1} \otimes \mathcal{F}_i^B, \quad (44)$$

and further define a quantum channel $\mathcal{E}^{R_0 \rightarrow R_1 A_1} = \sum_i \Gamma_i^R \otimes |i\rangle\langle i|^{A_1}$. Then we have $\mathbb{1}^R \otimes \Theta^{A_1 \rightarrow B}[\mathcal{E}] = \mathcal{G}^{RB}$. It is obvious that $\Theta^{A_1 \rightarrow B}$ is an MPSC, and so $\mathcal{G} \in \mathcal{C}_{\text{MPSC}}$. Combining the above results we get $\mathcal{C}_{\text{MPSC}} = \text{LOCC}_1$.

As for $\mathcal{C}_{\text{CMPSC}} \subsetneq \mathcal{C}_{\text{EBSC}}$, recall the EBSC we constructed to prove Theorem 4. By applying that EBSC at an input noiseless channel $\text{id}^{R_0 \rightarrow A_1}$, we obtain a separable channel that cannot be implemented by LOCC. This complete the proof of proposition 5.1. \square

The above proposition precisely characterizes the CPTP-complete image of MPSC and CMPSC. Also, it tells us $\mathcal{C}_{\text{EBSC}}$ contains all $(B \rightarrow R \rightarrow B)$ two-round LOCC channels and some non-LOCC separable channels. It remains an open problem whether $\mathcal{C}_{\text{EBSC}} = \text{SEP}$. We next turn to the CP-complete image.

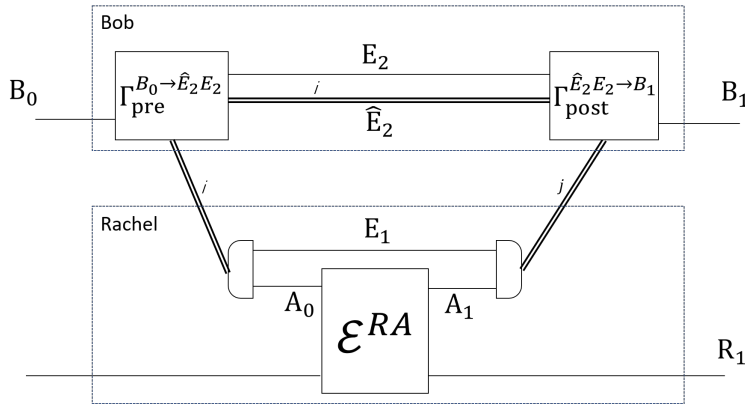

Figure 13: A CMPSC superchannel transforms any \mathcal{E}^{RA} into a channel \mathcal{F}^{RB} that can implemented by a two-round LOCC channel from Bob to Rachel.

5.2 CP-complete Image of EBSC

Interestingly, we can easily prove $C_{\text{EBSC}}^* = \text{SEP}^*$. We first present a proof by direct construction, and then later discuss how this result is related to the notion of stochastic LOCC (SLOCC) strategy.

Proposition 5.2. *The CP-complete image of EBSC and CMPSC satisfy*

$$C_{\text{CMPSC}}^* = C_{\text{EBSC}}^* = \text{SEP}^*, \quad (45)$$

where SEP^* is the set of all bipartite separable CP maps.

Proof. By definition, $C_{\text{EBSC}}^* \subseteq \text{SEP}^*$. We only need to prove that $C_{\text{EBSC}}^* \supseteq \text{SEP}^*$. It is enough to show that C_{EBSC}^* contains all CPTNI separable maps, because every CP map can be normalized to be CPTNI by dividing a positive factor, and we can always multiply this factor to the input CP map.

For any bipartite separable CPTNI map \mathcal{G}^{RB} , its Choi matrix can be written as $J_{\mathcal{G}}^{RB} = \sum_{k=1}^r P_k^{R_0 R_1} \otimes Q_k^{B_0 B_1}$ such that P_k, Q_k are positive operators. Without loss of generality we take $\text{Tr}(P_k) = 1$. Since \mathcal{G}^{RB} is CPTNI, we have $\sum_k P_k^{R_0} \otimes Q_k^{B_0} \leq I^{R_0 B_0}$, and so $\sum_k Q_k^{B_0} \leq I^{B_0}$. Let $F^{B_0 B_1}$ be a positive operator satisfying $F^{B_0} = I^{B_0} - \sum_k Q_k^{B_0}$. Then for an $(r+1)$ -dimensional system A_0 and system A_1 being one-dimensional, construct a supermap Θ whose Choi matrix is as follows.

$$\mathcal{J}_{\Theta}^{AB} = \sum_{k=1}^r |k\rangle\langle k|^{A_0} \otimes Q_k^{B_0 B_1} + |r+1\rangle\langle r+1|^{A_0} \otimes F^{B_0 B_1}. \quad (46)$$

Since A_1 is one-dimensional, it holds trivially that $\mathcal{J}_{\Theta}^{AB_0} = \mathcal{J}_{\Theta}^{A_0 B_0} \otimes u^{A_1}$ and $\mathcal{J}_{\Theta}^{A_1 B_0} = I^{A_1 B_0}$, and hence Θ is a superchannel. Furthermore, since $\mathcal{J}_{\Theta}^{AB}$ is separable with respect to $A : B$, it is also an EBSC, by Theorem 1. Define a CP map \mathcal{E} whose Choi matrix is given by

$$J_{\mathcal{E}}^{RA} = \sum_{k=1}^r P_k^R \otimes |k\rangle\langle k|^{A_0}. \quad (47)$$

Note the condition $\sum_k P_k^{R_0} = I$ need not be enforced here since we allow \mathcal{E} to be non-trace-preserving. Then,

$$J_{\mathbb{1} \otimes \Theta[\mathcal{E}]}^{RB} = \text{Tr}_A \left(\mathcal{J}_{\Theta}^{AB} \left(J_{\mathcal{E}}^{RA} \right)^{\Gamma_A} \right) \quad (48)$$

$$= \sum_k P_k^R \otimes Q_k^B = J_{\mathcal{G}}^{RB}, \quad (49)$$

hence $\mathcal{G} = \mathbb{1} \otimes \Theta[\mathcal{E}]$. By the arbitrariness of \mathcal{G} and the argument before, we have $\text{SEP}^* \subseteq C_{\text{EBSC}}^*$, hence $C_{\text{EBSC}}^* = \text{SEP}^*$.

Notice that the EBSC Θ in the above proof is actually a CMPSC. To see this, take the pre/post-processing map to be

$$\Gamma_{\text{pre}}^{B_0 \rightarrow A_0 E} = \sum_{k=1}^r \Lambda_k^{B_0 \rightarrow E} \otimes |k\rangle\langle k|^{A_0} + \mathcal{F}^{B_0 \rightarrow E} \otimes |r+1\rangle\langle r+1|^{A_0}, \quad (50)$$

$$\Gamma_{\text{post}}^{A_1 E \rightarrow B_1} = \text{id}^{E \rightarrow B_1} \otimes \text{Tr}_{A_1}, \quad (51)$$

where $\Lambda_k^{B_0 \rightarrow E}$ (resp. $\mathcal{F}^{B_0 \rightarrow E}$) is the unique map with Choi matrix $Q_k^{B_0 E}$ (resp. $F^{B_0 E}$). It is easy to check $\Gamma_{\text{pre}}^{B_0 \rightarrow A_0 E}$ is CPTP. Therefore, we have $C_{\text{CMPSC}}^* = C_{\text{EBSC}}^* = \text{SEP}^*$. This complete the proof of Proposition 5.2. \square

It is interesting to consider the physical interpretation of the superchannel and input CP used in the previous proof. In order to implement the CPTNI map $\mathcal{G}^{RB} = \sum_{k=1}^r P_k^R \otimes Q_k^B$, Bob first performs a quantum instrument $\{\Lambda_1, \dots, \Lambda_r, \mathcal{F}\}$ and sends the outcome (stored as classical information in system A_0) to Rachel. Rachel then acts as follows. If Bob's action is Λ_k , Rachel implements the CPTNI map with Choi matrix P_k to complete the procedure. If Bob's action is \mathcal{F} , the protocol aborts. Of course, it may only be possible for Rachel to implement the CPTNI map P_k with some nonzero probability. In this case, Rachel needs an extra round of classical communication to let Bob know whether her implementation is successful. Bob's final CPTP map would then be the identity in the case that she succeeds, and some other fixed "failure" channel in the case that she does not.

The above procedure describes a general stochastic LOCC (SLOCC) protocol. It is shown in [29] that every separable map can be implemented by an SLOCC protocol, which provides a rough explanation for why Proposition 5.2 holds. It also helps shed light on the physical significance of CP image, as defined in Definition 5.2. This is related to stochastic quantum processes, which we discuss further in the next subsection.

5.3 Discussion on CP Image

Suppose that, for superchannel $\Theta^{A \rightarrow B}$ and CP maps \mathcal{G}^B and \mathcal{E}^A one has

$$\mathcal{G}^B = \Theta^{A \rightarrow B}[\mathcal{E}^A]. \quad (52)$$

If both \mathcal{G} and \mathcal{E} are CPTP, the physical interpretation of this equation is clearly deterministic channel conversion. What if they are not trace-preserving? Let us consider the case when \mathcal{G}^B is CPTNI and \mathcal{E}^A is a general CP map. We can always find a positive number $p \leq 1$ such that $p\mathcal{E}$ is a CPTNI map, hence we can find another CPTNI map \mathcal{T} to make up a quantum instrument $\{p\mathcal{E}, \mathcal{T}\}^A$. By applying $\Theta^{A \rightarrow B}$ to this instrument (see Fig. 14) we get a new instrument $\{p\mathcal{G}, \Theta[\mathcal{T}]\}^B$. This provides an implementation of the CPTNI map \mathcal{G} with success probability p . Therefore, the physical interpretation of the above equation is probabilistic channel conversion. Hence the CPTP (resp. CP) image describes the channels (resp. CP maps) that can be deterministically (resp. probabilistically) generated by a superchannel.

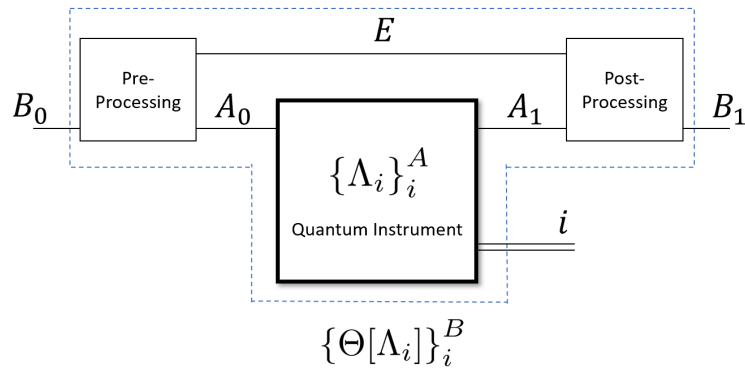

Figure 14: A quantum instrument $\{\Theta[\Lambda_i]\}_i^B$ resulting from applying superchannel $\Theta^{A \rightarrow B}$ at a bipartite quantum instrument $\{\Lambda_i\}_i^A$.

Comparing Propositions 5.1 and 5.2, which say that $C_{\text{CMPSC}} = \text{LOCC}_2$ but $C_{\text{CMPSC}}^* = \text{SEP}^*$, we see that there are CPTP maps that can be probabilistically implemented by CMPSC but not deterministically, since there are non-LOCC CPTP maps in

$\text{SEP} \subset \text{SEP}^*$ that are not in LOCC_2 . Hence, there are separable channels \mathcal{G}^{RB} and valid superchannels $\Theta^{A \rightarrow B}$ for which $\mathcal{G}^{RB} = \mathbb{1}^R \otimes \Theta^{A \rightarrow B}[\mathcal{E}^{RA}]$ holds only for some CP non-TP map \mathcal{E}^{RA} . Such a phenomenon does not exist at the level of channels and states because we cannot transform an unnormalized state into a normalized one by a quantum channel. This result shows that the structure of unnormalized maps is much more complex than the structure of unnormalized states, which is one of the reasons why QRTs of channels are often more challenging to formalize than QRTs of states (see also Ref. [17] for a related discussion on this point).

6 Alternative definitions of entanglement breaking

In the final section, we examine certain relaxations to the definition of entanglement breaking. To this end, we first consider relaxations to separable channels. Recall that a bipartite channel $\mathcal{E} \in \text{CP}(A_0 R_0 \rightarrow A_1 R_1)$ is separable if $\sigma^{R' A' R_1 A_1} = \text{id}^{R' A'} \otimes \mathcal{E}^{A_0 R_0 \rightarrow A_1 R_1}(\rho^{R' R_0} \otimes \omega^{A' A_0})$ is $R' R_1 : A' A_1$ separable for all $\rho^{R' R_0} \otimes \omega^{A' A_0}$ and all systems R' and A' . In fact, it suffices to consider systems R' and A' of dimension d_{R_0} and d_{A_0} , respectively. A relaxation would be to require that $\sigma^{R' A' R_1 A_1}$ is separable only for systems R' and A' of smaller dimension.

Definition 6.1. *A bipartite channel $\mathcal{E} \in \text{CP}(A_0 R_0 \rightarrow A_1 R_1)$ is called (p, q) -non-entangling if $\text{id}^{R' A'} \otimes \mathcal{E}^{A_0 R_0 \rightarrow A_1 R_1}(\rho^{R' R_0} \otimes \omega^{A' A_0})$ is $R' R_1 : A' A_1$ separable for all $\rho^{R' R_0} \otimes \omega^{A' A_0}$ with any systems R' and A' of dimension $d_{A'} = p$ and $d_{R'} = q$.*

A (k, k) -non-entangling channel is also called k -non-entangling in previous literature [30]. We call a channel $(p, \text{complete})$ -non-entangling if it is (p, q) -non-entangling for every positive integer q . A separable channel is then a $(\text{complete}, \text{complete})$ -non-entangling channel.

Definition 6.2. *A superchannel $\Theta^{A \rightarrow B}$ is called a (p, q) -EBSC if $\mathbb{1}^R \otimes \Theta^{A \rightarrow B}[\mathcal{E}^{RA}]$ is a (p, q) -non-entangling map (p with B and q with R) for every $\mathcal{E} \in \text{CP}(RA)$, with R being an arbitrary finite-dimensional system.*

Although the general structure of (p, q) -EBSCs could be rather complicated, we can obtain some decent results when restricting our attention to superchannels that have an implementation without a side-channel (see Def 6.4 below), and only $(k, \text{complete})$ -EBSCs. Before doing that, we first introduce a class of k -entanglement breaking channels in the following subsection.

6.1 k -Entanglement Breaking Channel

Definition 6.3. [31] *A quantum channel $\Lambda \in \text{CPTP}(B_0 \rightarrow B_1)$ is called a k -entanglement breaking channel (k -EBC) if $\text{id}^R \otimes \Lambda(\rho)$ is separable for any $\rho \in \mathcal{D}(R \otimes B_0)$, where R is any k -dimensional Hilbert space.*

This class of k -EBC was first introduced in [31] to study the condition when concatenated maps become entanglement breaking. Note that, this definition differs from the k -partially entanglement-breaking channel studied in Ref. [32], which is a channel $\Lambda^{B_0 \rightarrow B_1}$ that satisfies $\text{SN}(\text{id}^R \otimes \Lambda(\rho)) \leq k$ for any $\rho \in \mathcal{D}(R \otimes B_0)$ with arbitrarily large system R , where SN denotes the Schmidt number.

For simplicity, in the following we only consider channels with the same input and output dimension, $d \geq 2$. A k -EBC is a completely-EBC whenever $k \geq d$ [3]. For $1 \leq$

$k < d$, the set of k -EBC is clearly a subset of $(k+1)$ -EBC, and the set of all 1-EBCs trivially equals $\text{CPTP}(B_0 \rightarrow B_1)$. To summarize, we have

$$\text{completely-EBC} = d\text{-EBC} \subseteq (d-1)\text{-EBC} \subseteq \dots \subseteq 1\text{-EBC} = \text{CPTP}. \quad (53)$$

In Theorem 6 below, we show that each of the above inclusions is strict. That is, there exists a k -EBC that is not $(k+1)$ -EBC for all $1 \leq k < d$.

Theorem 6. *For all integers k and d with $1 \leq k < d$, there exists a k -EBC $\Lambda \in \text{CPTP}(\mathbb{C}^d \rightarrow \mathbb{C}^d)$ that is not $(k+1)$ -EBC.*

The proof of this theorem is inspired by Theorem 20 in [30], which establishes the existence of k -non-entangling map that is not $(k+1)$ -non-entangling. Interestingly, Theorem 20 in [30] turns out to be a corollary of Theorem 6 presented here.

Corollary 6.1. [30] *For all integers k and d with $1 \leq k < d$, there exists a k -non-entangling map $\Lambda : \mathcal{L}(\mathbb{C}^d \otimes \mathbb{C}^d) \rightarrow \mathcal{L}(\mathbb{C}^d \otimes \mathbb{C}^d)$ that is not $(k+1)$ -non-entangling.*

Proof. The channel $\text{SWAP} \circ (\Lambda \otimes \Lambda)$ with k -EBC but not $(k+1)$ -EBC Λ is by definition k -non-entangling but not $(k+1)$ -non-entangling map, for all $1 \leq k < d$. \square

Now we set out to prove Theorem 6. In the following, we assume $\mathcal{H}_R = \mathbb{C}^k$ and $\mathcal{H}_{B_0} = \mathcal{H}_{B_1} = \mathbb{C}^d$ and $\Lambda \in \text{CPTP}(B_0 \rightarrow B_1)$. First notice that, in order to prove a channel Λ is k -EBC, it suffices to show $\text{id}_R \otimes \Lambda(\varphi)$ is separable for all pure states $|\varphi\rangle \in \mathcal{H}_R \otimes \mathcal{H}_{B_0}$, since we can then apply convexity to cover mixed states. Any such pure state can be written as

$$|\varphi\rangle = X \otimes \text{id}_d |\phi_d^+\rangle \quad (54)$$

for some operator $X \in \mathcal{L}(\mathbb{C}^d \rightarrow \mathbb{C}^k)$. Let $X = \sum_{i=1}^r \lambda_i |\alpha_i\rangle\langle\beta_i|$ denote a singular value decomposition of X , and define $X^{-1} := \sum_{i=1}^r \lambda_i^{-1} |\beta_i\rangle\langle\alpha_i|$ (with $\lambda_i > 0$ for $i = 1, \dots, r$). Then $X^{-1}X = P = \sum_{i=1}^r |\beta_i\rangle\langle\beta_i|$ is a projector of rank $r \leq k$. Then since local operators preserve separability, we have that

$$\text{id} \otimes \Lambda[|\phi\rangle\langle\phi|] = \text{id} \otimes \Lambda[(X \otimes \mathbb{I}_d)\phi_d^+(X \otimes I_d)^\dagger]$$

is separable if and only if

$$(X^{-1} \otimes \mathbb{I})\text{id} \otimes \Lambda[(X \otimes \mathbb{I}_d)\phi_d^+(X \otimes I_d)^\dagger](X^{-1} \otimes I)^\dagger = (P \otimes \text{id}_d)J_\Lambda(P^\dagger \otimes \text{id}_d) \quad (55)$$

is separable. We summarize this observation in the following lemma.

Lemma 6.1. *A channel $\Lambda \in \text{CPTP}(B_0 \rightarrow B_1)$ is k -EBC if and only if the operator*

$$(P \otimes I_d)J_\Lambda(P^\dagger \otimes I_d) \quad (56)$$

is separable for all projectors P with dimension no larger than k .

Now we introduce the Werner states [33] which will play an important role in our construction of k -EBC. The Werner states are a family of states on $\mathbb{C}^d \otimes \mathbb{C}^d$ which take the following form,

$$\rho_d^{\mathcal{W}}(\beta) = \frac{1}{d^2 - (\beta + 1)} \left(I_{d^2} - \frac{\beta + 1}{d} F_d \right), \quad (57)$$

for $-(d+1) \leq \beta \leq d-1$, where $F_d = \sum_{ij} |i\rangle\langle j| \otimes |j\rangle\langle i|$ is the swap operator (or the partial transpose of ϕ_d^+). A crucial observation is that the partial trace of a Werner state

is $\frac{1}{d}I_d$, which means it is a valid Choi matrix of some CPTP quantum channel (with some normalization). Specifically, consider the following map,

$$\Lambda_\beta(\rho_{B_0}) := d \operatorname{Tr}_{B_0}[\rho_d^{\mathcal{W}}(\beta)(\rho_{B_0}^T \otimes I_{B_1})]. \quad (58)$$

This map is clearly completely positive, and it is also trace-preserving since

$$\begin{aligned} \operatorname{Tr}(\Lambda_\beta(\rho_{B_0})) &= \operatorname{Tr}[d \operatorname{Tr}_{B_1}(\rho_d^{\mathcal{W}}(\beta)) \rho_{B_0}] \\ &= \operatorname{Tr}(I_d \rho_{B_0}) \\ &= \operatorname{Tr}(\rho_{B_0}), \end{aligned} \quad (59)$$

where the second equation is from our observation on the partial trace of Werner states. We conclude that $\Lambda_\beta \in \text{CPTP}(B_0 \rightarrow B_1)$.

Since $\rho_d^{\mathcal{W}}(\beta)$ is the Choi matrix of Λ_β up to normalization, we can apply Lemma 6.1 by studying the separability properties of $\rho_d^{\mathcal{W}}(\beta)$. The following lemma is modified from Lemma 19 in [30].

Lemma 6.2. *Let k and d be integers such that $1 \leq k < d$ and let $-(d+1) \leq \beta \leq d-1$. The operator*

$$\rho_{RB_1}^{\text{proj}} := (P \otimes I_d) \rho_d^{\mathcal{W}}(\beta) (P \otimes I_d)$$

is separable for all projectors P with dimension no greater than k if and only if $\beta \leq (d-k)/k$.

Proof. (Proof of lemma 6.2) We first require P to be a k -dimensional projector in $\mathcal{L}(B_0 \rightarrow B_1)$. By direct calculation, we have

$$\rho_{RB_1}^{\text{proj}} \propto I_{kd} - \frac{\beta+1}{d} \left((P \otimes I_d) F_d(P^\dagger \otimes I_d) \right) \quad (60)$$

$$= I_{kd} - \frac{\beta+1}{d} \left((P^* \otimes I_d) \phi_d^+(P^T \otimes I_d) \right)^\Gamma \quad (61)$$

$$= I_{kd} - \frac{\beta+1}{d} c \psi^\Gamma, \quad (62)$$

for some normalized pure state $|\psi\rangle = (P^* \otimes \text{id}_d) |\phi_d^+\rangle / \sqrt{c}$, with normalizing factor

$$c = \operatorname{Tr} \left((P^* \otimes I_d) \phi_d^+(P^T \otimes I_d) \right) \quad (63)$$

$$= \operatorname{Tr}(\overline{P}P^T) = \operatorname{Tr}(PP^\dagger) = k. \quad (64)$$

If $\beta > (d-k)/k$, then $\frac{\beta+1}{d}k > 1$ and so

$$\left(\rho_{RB_1}^{\text{proj}} \right)^\Gamma = I_{kd} - \frac{\beta+1}{d} k \psi \quad (65)$$

is obviously not positive. A non-positive partial transpose implies that $\rho_{RB_1}^{\text{proj}}$ is entangled. On the other hand, if $\beta \leq (d-k)/k$, we apply Theorem 1 from [34] which states that the operator $\text{id} + A$ is separable for all Hermitian A with $\|A\|_2 \leq 1$, where $\|A\|_2 = \sqrt{\operatorname{Tr} A^\dagger A}$ is the Frobenius norm. Here, we have

$$\left\| \frac{\beta+1}{d} k \psi^\Gamma \right\|_2 \leq \|\psi^\Gamma\|_2 = \|\psi\|_2 = 1, \quad (66)$$

since ψ is a normalized pure state. We therefore conclude that $\rho_{RB_1}^{\text{proj}}$ is separable. This establishes that $\rho_{RB_1}^{\text{proj}}$ is separable for all k -dimensional projectors P if and only if $\beta \leq (d-k)/k$. Since any projector of dimension strictly less than k can be implemented by first performing a k -dimensional projector and then projecting into a smaller subspace, it immediately follows that $\rho_{RB_1}^{\text{proj}}$ is separable for all projectors P of dimension no greater than k if and only if $\beta \leq (d-k)/k$. This completes the proof of Lemma 6.2. \square

As a direct result of Lemma 6.1 and Lemma 6.2, the channel Λ_β constructed in Eq. (58) is k -EBC if and only if $\beta \leq (d-k)/k$, for $1 \leq k < d$. This completes the proof of Theorem 6.

Finally, we note that, a special case of Theorem 6 for 2-EBCs is also established in [31, Corollary III.4] using the Holevo-Werner maps similar as in the above proof.

6.2 Interplay between k -EBC and $(k, \text{complete})$ -EBSC

In this subsection, we discuss the interplay between generalized EBC and generalized EBSC. For simplicity, the systems A, B , we consider are both required to have d -dimensional input and output systems. We will also restrict attention to the special class of superchannels that allow for a realization without the side-channel E .

Definition 6.4. A superchannel Θ is said to be *without side-channel*, if it can be realized as

$$\Theta^{A \rightarrow B}[\mathcal{E}^A] = \Gamma_{\text{post}}^{A_1 \rightarrow B_1} \circ \mathcal{E}^A \circ \Gamma_{\text{pre}}^{B_0 \rightarrow A_0} \quad (67)$$

for some CPTP maps Γ_{pre} and Γ_{post} .

Corollary 6.2. If an EBSC $\Theta^{A \rightarrow B}$ has a realization without side-channel as in Eq. (67), then both $\Gamma_{\text{pre}}^{B_0 \rightarrow A_0}$ and $\Gamma_{\text{post}}^{A_1 \rightarrow B_1}$ must be entanglement breaking channels.

Proof. This simply follows from Thm. 1. (D) and the definition of EB channels. \square

The following proposition discusses the relation between k -EBC and $(k, \text{complete})$ -EBSC, for any positive integer $k \leq d$.

Proposition 6.1. For a superchannel $\Theta^{A \rightarrow B}$ without side-channel as in Eq. (67), the following are equivalent.

- (A) $\Theta^{A \rightarrow B}$ is a $(k, \text{complete})$ -EBSC.
- (B) $\Gamma_{\text{pre}}^{B_0 \rightarrow A_0}$ is a k -EBC, and $\Gamma_{\text{post}}^{A_1 \rightarrow B_1}$ is a completely-EBC.

As a result, the realization of a $(k, \text{complete})$ -EBSC without side-channel is shown in Fig. 15.

Proof. (A) \Rightarrow (B): Choose system R to have $d_{R_0} = d_{R_1} = d$, Let D be a d -dimensional system, K be a k -dimensional system. Consider the CP map $\Phi_+^{RA}(\cdot) = \text{Tr}((\cdot)\phi_+^{R_0 A_0})\phi_+^{R_1 A_1}$, the maximally entangled state $\phi_+^{R_0 D}$, and an arbitrary quantum state $\rho \in \mathcal{D}(B_0 K)$. We have

$$\left(\text{id}^{KD} \otimes (\mathbb{1}^R \otimes \Theta^{A \rightarrow B}[\Phi_+^{RA}]) \right) (\rho^{B_0 K} \otimes \phi_+^{R_0 D}) \quad (68)$$

$$= \Gamma_{\text{pre}}^{B_0 \rightarrow D}(\rho^{B_0 K}) \otimes \Gamma_{\text{post}}^{A_1 \rightarrow B_1}(\phi_+^{R_1 A_1}). \quad (69)$$

Since Θ is $(k, \text{complete})$ -EBSC, the above state must be separable with respect to $KB_1 : DR_1$, which means both $\Gamma_{\text{pre}}^{B_0 \rightarrow D}(\rho^{B_0 K})$ and $\Gamma_{\text{post}}^{A_1 \rightarrow B_1}(\phi_+^{R_1 A_1})$ are separable. The former

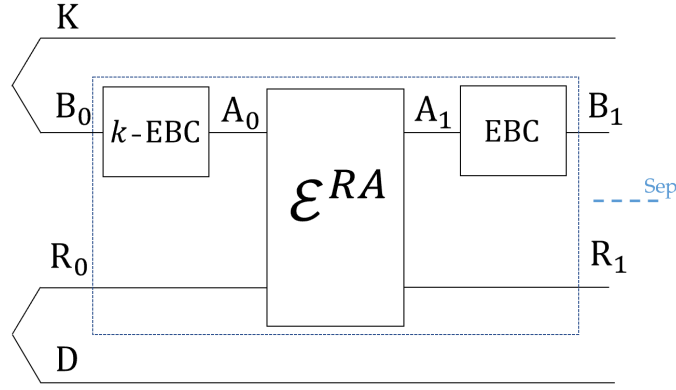

Figure 15: Realization of a $(k, \text{complete})$ -EBSC without side-channel (in the blue dash box).

implies Γ_{pre} is k -EBC since ρ is an arbitrary state on B_0K . The latter implies Γ_{post} is (completely) EBC by Proposition. 2.1 [3]. This complete the proof of $(A) \Rightarrow (B)$.

$(B) \Rightarrow (A)$: Consider the circuit in Fig. 15. For any separable input $\rho^{B_0K} \otimes \varphi^{R_0D}$, it is easy to see the output state is $K : B_1 : R_1D$ separable, which means $\Theta^{A \rightarrow B}$ is indeed (k, d) -EBSC. \square

Since the hierarchy of k -EBC is non-trivial, there is also a non-trivial hierarchy of $(k, \text{complete})$ -EBSC, for $1 \leq k \leq d$.

As a final comment, the series of study about when composed maps become entanglement breaking [31, 35–39] may also be generalized to supermaps. As an example, the Schmidt number iteration theorem [31] can be directly applied here to get the following corollary.

Corollary 6.3. *If $\Theta^{A \rightarrow A}$ is a $(k, \text{complete})$ -EBSC without side-channel and M is an integer no less than $\lceil \frac{d-1}{k-1} \rceil$, then an M times concatenation of Θ as*

$$\Theta^M \equiv \underbrace{\Theta \circ \Theta \circ \dots \circ \Theta}_{M \text{ times}}$$

is an EBSC.

Proof. The Schmidt number iteration theorem [31] states that a $\lceil \frac{d-1}{k-1} \rceil$ times concatenation of a k -EBC \mathcal{E}^A becomes completely-EB. Combining it with Proposition 6.1 gives this corollary. \square

We leave the question when general composed superchannels become EBSC as an interesting future research direction.

7 Conclusion and Discussion

In this paper, we introduce and thoroughly study the notion of entanglement-breaking superchannels (EBSCs). These are objects that generalize and extend the standard notion of entanglement-breaking channels (EBCs) to “higher-order” quantum maps. On the one hand, EBSCs (and EB supermaps) allow for relatively simple characterization via the Choi matrix, just like its channel counterpart. On the other hand, they can also exhibit some interesting properties, which make them much more complex than EBCs in many

aspects. Firstly, we show that all entanglement-breaking supermaps can be decomposed into partly-EB pre/post-processing CP maps. While left open the question whether every EBSC can be implemented with partly-EB pre/post-processing channels, we show that a generic implementation must allow entangling the input system to the memory system of a superchannel. Secondly, we show that EBSC is more general than measure-and-prepare superchannels (MPSCs), and even controlled-measure-and-prepare superchannels (CMPSCs), while for EBC these three classes coincide. Finally, we illustrate a super-activation phenomenon of EBSCs.

We further investigate which quantum channels can be generated using EBSCs, as well as the smaller classes of MPSCs and CMPSCs. We show that the CPTP-complete image of MPSC/CMPSC equals one/two-round LOCC maps, respectively. Although we are not able to precisely characterize the CPTP-complete image of EBSC, we show that its CP-complete image equals the collection of all separable maps. We argue that the notion of CP image captures some fundamental difference between channels and superchannels, and we hope these results might inspire new lines of investigation into probabilistic channel conversion.

In the final section of this paper, we establish a relationship between k -EBC, k -non-entangling channel and $(k, \text{complete})$ -EBSC without side-channel. By generalizing the method of [30], we show that all these three objects have a non-trivial hierarchy for $1 \leq k \leq d$. We remark that other alternative definitions of EBSC are also possible. One can require the output of EBSC to be not only separable, but also LOCC, or even LOSR (local operations and shared randomness). In this sense, our definition of MPSC (CMPSC) is just an example of one-round (two-round) LOCC-EBSC, but it remains unclear whether every one-round (two-round) LOCC-EBSC can be realized this way. In other words, whether $\text{MPSC} \subseteq \text{LOCC}_1\text{-EBSC}$ and $\text{CMPSC} \subseteq \text{LOCC}_2\text{-EBSC}$ are strict inclusions needs further investigation.

Our work provides a useful tool for the dynamical resource theory of quantum entanglement. Many results in entanglement theory based on EBCs can possibly be generalized to the dynamical resource theory with EBSC. For example, inspired by the resource theory of quantum memory where EBCs are a free resource [40], one can consider the ability to faithfully store a quantum operation, perhaps call it a “super-memory”, where EBSC may serve as free resource. We leave this for future work. Also, since we have characterized the Choi matrix of an EBSC, it is straightforward to calculate a robustness-type quantity with respect to it, similar to what has been done in [41]. We anticipate there being other applications of EBSC within the study of dynamical quantum resource theories.

There are some problems left open in our work. The first is whether the deterministic image of EBSC equals the set of all separable channels, namely whether $C_{\text{EBSC}} = \text{SEP}$ or not. Currently we only know that all two-round LOCC and some non-LOCC separable channels are in C_{EBSC} . The second is whether every EBSC can be realized as in Fig. 6 with the pre/post-processing maps being CPTP. Answering these questions will help us better understand the intricate structure of EBSCs.

Acknowledgments

We thank the anonymous reviewers for their helpful suggestions to improve this paper. SC acknowledges the support from the Tsinghua Scholarship for Undergraduate Oversea Studies. EC is supported by the National Science Foundation (NSF) Award No. 1914440.

References

- [1] J. I. Cirac, W. Dür, B. Kraus, and M. Lewenstein. Entangling operations and their implementation using a small amount of entanglement. *Phys. Rev. Lett.*, 86:544–547, Jan 2001. DOI: [10.1103/PhysRevLett.86.544](https://doi.org/10.1103/PhysRevLett.86.544).
- [2] G. Chiribella, G. M. D’Ariano, and P. Perinotti. Transforming quantum operations: Quantum supermaps. *EPL (Europhysics Letters)*, 83(3):30004, jul 2008. DOI: [10.1209/0295-5075/83/30004](https://doi.org/10.1209/0295-5075/83/30004).
- [3] Michael Horodecki, Peter W. Shor, and Mary Beth Ruskai. Entanglement breaking channels. *Reviews in Mathematical Physics*, 15(06):629–641, 2003. DOI: [10.1142/S0129055X03001709](https://doi.org/10.1142/S0129055X03001709).
- [4] Eric Chitambar and Gilad Gour. Quantum resource theories. *Rev. Mod. Phys.*, 91:025001, Apr 2019. DOI: [10.1103/RevModPhys.91.025001](https://doi.org/10.1103/RevModPhys.91.025001).
- [5] Thomas Theurer, Dario Egloff, Lijian Zhang, and Martin B. Plenio. Quantifying operations with an application to coherence. *Phys. Rev. Lett.*, 122:190405, May 2019. DOI: [10.1103/PhysRevLett.122.190405](https://doi.org/10.1103/PhysRevLett.122.190405).
- [6] Graeme D Berk, Andrew JP Garner, Benjamin Yadin, Kavan Modi, and Felix A Pollock. Resource theories of multi-time processes: A window into quantum non-markovianity, 2019. arXiv:1907.07003.
- [7] Yunchao Liu and Xiao Yuan. Operational resource theory of quantum channels. *Physical Review Research*, 2(1):012035, 2020. DOI: [10.1103/PhysRevResearch.2.012035](https://doi.org/10.1103/PhysRevResearch.2.012035).
- [8] Zi-Wen Liu and Andreas Winter. Resource theories of quantum channels and the universal role of resource erasure. 2019. arXiv:1904.04201.
- [9] Gilad Gour and Andreas Winter. How to quantify a dynamical quantum resource. *Phys. Rev. Lett.*, 123:150401, Oct 2019. DOI: [10.1103/PhysRevLett.123.150401](https://doi.org/10.1103/PhysRevLett.123.150401).
- [10] Gilad Gour and Carlo Maria Scandolo. The entanglement of a bipartite channel. 2019. arXiv:1907.02552.
- [11] Stefan Bäuml, Siddhartha Das, Xin Wang, and Mark M. Wilde. Resource theory of entanglement for bipartite quantum channels. 2019. arXiv:1907.04181.
- [12] Andrzej Jamiołkowski. Linear transformations which preserve trace and positive semidefiniteness of operators. *Reports on Mathematical Physics*, 3(4):275–278, 1972. DOI: [10.1016/0034-4877\(72\)90011-0](https://doi.org/10.1016/0034-4877(72)90011-0).
- [13] Man-Duen Choi. Completely positive linear maps on complex matrices. *Linear algebra and its applications*, 10(3):285–290, 1975. DOI: [10.1016/0024-3795\(75\)90075-0](https://doi.org/10.1016/0024-3795(75)90075-0).
- [14] Vlatko Vedral, Martin B Plenio, Michael A Rippin, and Peter L Knight. Quantifying entanglement. *Physical Review Letters*, 78(12):2275, 1997. DOI: [10.1103/PhysRevLett.78.2275](https://doi.org/10.1103/PhysRevLett.78.2275).
- [15] Howard Barnum, M. A. Nielsen, and Benjamin Schumacher. Information transmission through a noisy quantum channel. *Phys. Rev. A*, 57:4153–4175, Jun 1998. DOI: [10.1103/PhysRevA.57.4153](https://doi.org/10.1103/PhysRevA.57.4153).
- [16] Gilad Gour. Comparison of quantum channels by superchannels. *IEEE Transactions on Information Theory*, 65(9):5880–5904, 2019. DOI: [10.1109/TIT.2019.2907989](https://doi.org/10.1109/TIT.2019.2907989).
- [17] John Burniston, Michael Grabowecky, Carlo Maria Scandolo, Giulio Chiribella, and Gilad Gour. Necessary and sufficient conditions on measurements of quantum channels. *Proceedings of the Royal Society A*, 476(2236):20190832, 2020. DOI: [10.1098/rspa.2019.0832](https://doi.org/10.1098/rspa.2019.0832).
- [18] Giulio Chiribella, Giacomo M D’Ariano, and Paolo Perinotti. Memory effects in

- quantum channel discrimination. *Physical review letters*, 101(18):180501, 2008. DOI: [10.1103/PhysRevLett.101.180501](https://doi.org/10.1103/PhysRevLett.101.180501).
- [19] Mário Ziman. Process positive-operator-valued measure: A mathematical framework for the description of process tomography experiments. *Phys. Rev. A*, 77:062112, Jun 2008. DOI: [10.1103/PhysRevA.77.062112](https://doi.org/10.1103/PhysRevA.77.062112).
- [20] Gus Gutoski and John Watrous. Toward a general theory of quantum games. In *Proceedings of the thirty-ninth annual ACM symposium on Theory of computing*, pages 565–574, 2007. DOI: [10.1145/1250790.1250873](https://doi.org/10.1145/1250790.1250873).
- [21] Charles H. Bennett, David P. DiVincenzo, Christopher A. Fuchs, Tal Mor, Eric Rains, Peter W. Shor, John A. Smolin, and William K. Wootters. Quantum nonlocality without entanglement. *Phys. Rev. A*, 59:1070–1091, Feb 1999. DOI: [10.1103/PhysRevA.59.1070](https://doi.org/10.1103/PhysRevA.59.1070).
- [22] Asher Peres and William K. Wootters. Optimal detection of quantum information. *Phys. Rev. Lett.*, 66:1119–1122, Mar 1991. DOI: [10.1103/PhysRevLett.66.1119](https://doi.org/10.1103/PhysRevLett.66.1119).
- [23] Eric Chitambar and Min-Hsiu Hsieh. Revisiting the optimal detection of quantum information. *Phys. Rev. A*, 88:020302, Aug 2013. DOI: [10.1103/PhysRevA.88.020302](https://doi.org/10.1103/PhysRevA.88.020302).
- [24] G. Chiribella, G. M. D’Ariano, and P. Perinotti. Quantum circuit architecture. *Phys. Rev. Lett.*, 101:060401, Aug 2008. DOI: [10.1103/PhysRevLett.101.060401](https://doi.org/10.1103/PhysRevLett.101.060401).
- [25] Giulio Chiribella, Giacomo Mauro D’Ariano, and Paolo Perinotti. Theoretical framework for quantum networks. *Phys. Rev. A*, 80:022339, Aug 2009. DOI: [10.1103/PhysRevA.80.022339](https://doi.org/10.1103/PhysRevA.80.022339).
- [26] Gus Gutoski. On a measure of distance for quantum strategies. *Journal of Mathematical Physics*, 53(3):032202, 2012. DOI: [10.1063/1.3693621](https://doi.org/10.1063/1.3693621).
- [27] Gus Gutoski. *Quantum strategies and local operations*. PhD thesis, University of Waterloo, 2009. Available at arXiv.org e-Print quant-ph/1003.0038.
- [28] Eric Chitambar, Debbie Leung, Laura Mančinská, Maris Ozols, and Andreas Winter. Everything you always wanted to know about LOCC (but were afraid to ask). *Communications in Mathematical Physics*, 328(1):303–326, May 2014. DOI: [10.1007/s00220-014-1953-9](https://doi.org/10.1007/s00220-014-1953-9).
- [29] W. Dür, G. Vidal, and J. I. Cirac. Three qubits can be entangled in two inequivalent ways. *Phys. Rev. A*, 62:062314, Nov 2000. DOI: [10.1103/PhysRevA.62.062314](https://doi.org/10.1103/PhysRevA.62.062314).
- [30] Eric Chitambar, Julio I de Vicente, Mark W Girard, and Gilad Gour. Entanglement manipulation beyond local operations and classical communication. *Journal of Mathematical Physics*, 61(4):042201, 2020. DOI: [10.1063/1.5124109](https://doi.org/10.1063/1.5124109).
- [31] Matthias Christandl, Alexander Müller-Hermes, and Michael M Wolf. When do composed maps become entanglement breaking? In *Annales Henri Poincaré*, volume 20, pages 2295–2322. Springer, 2019. DOI: [10.1007/s00023-019-00774-7](https://doi.org/10.1007/s00023-019-00774-7).
- [32] Dariusz Chruściński and Andrzej Kossakowski. On partially entanglement breaking channels. *Open Systems & Information Dynamics*, 13(1):17–26, Mar 2006. ISSN 1573-1324. DOI: [10.1007/s11080-006-7264-7](https://doi.org/10.1007/s11080-006-7264-7).
- [33] Reinhard F. Werner. Quantum states with einstein-podolsky-rosen correlations admitting a hidden-variable model. *Phys. Rev. A*, 40:4277–4281, Oct 1989. DOI: [10.1103/PhysRevA.40.4277](https://doi.org/10.1103/PhysRevA.40.4277).
- [34] Leonid Gurvits and Howard Barnum. Largest separable balls around the maximally mixed bipartite quantum state. *Phys. Rev. A*, 66:062311, Dec 2002. DOI: [10.1103/PhysRevA.66.062311](https://doi.org/10.1103/PhysRevA.66.062311).
- [35] M Christandl. PPT square conjecture. In *Banff International Research Station workshop: Operator structures in quantum information theory*, 2012.

- [36] Ludovico Lami and Vittorio Giovannetti. Entanglement-breaking indices. *Journal of Mathematical Physics*, 56(9):092201, 2015. DOI: [10.1063/1.4931482](https://doi.org/10.1063/1.4931482).
- [37] Ludovico Lami and Vittorio Giovannetti. Entanglement-saving channels. *Journal of Mathematical Physics*, 57(3):032201, 2016. DOI: [10.1063/1.4942495](https://doi.org/10.1063/1.4942495).
- [38] Mizanur Rahaman, Samuel Jaques, and Vern I Paulsen. Eventually entanglement breaking maps. *Journal of Mathematical Physics*, 59(6):062201, 2018. DOI: [10.1063/1.5024385](https://doi.org/10.1063/1.5024385).
- [39] Matthew Kennedy, Nicholas A. Manor, and Vern I. Paulsen. Composition of ppt maps. *Quantum Info. Comput.*, 18(5-6):472–480, 2018.
- [40] Denis Rosset, Francesco Buscemi, and Yeong-Cherng Liang. Resource theory of quantum memories and their faithful verification with minimal assumptions. *Phys. Rev. X*, 8:021033, May 2018. DOI: [10.1103/PhysRevX.8.021033](https://doi.org/10.1103/PhysRevX.8.021033).
- [41] Xiao Yuan, Yunchao Liu, Qi Zhao, Bartosz Regula, Jayne Thompson, and Mile Gu. Universal and operational benchmarking of quantum memories, 2019. arXiv:1907.02521.